

**COMPANION Z SUPPLEMENT=>**

## A FEW WORDS ABOUT SAFETY

### SERVICE INFORMATION

The service and repair information contained in this manual is intended for use by qualified, professional technicians. Attempting service or repairs without the proper training, tools, and equipment could cause injury to you and/or others. It could also damage the generator or create an unsafe condition.

This manual describes the proper methods and procedures for performing service, maintenance, and repairs. Some procedures require the use of special tools. Any person who intends to use a replacement part, service procedure, or a tool that is not recommended by Honda must determine the risks to their personal safety and the safe operation of the generator.

If you need to replace a part, use Honda Genuine parts with the correct part number, or an equivalent part. We strongly recommend that you do not use replacement parts of inferior quality.

### For Your Customer's Safety

Proper service and maintenance are essential to the customer's safety and the reliability of the generator. Any error or oversight while servicing the generator can result in faulty operation, damage to the generator, or injury to others.

### For Your Safety

Because this manual is intended for the professional service technician, we do not provide warnings about many basic shop safety practices (e.g., Hot parts – wear gloves). If you have not received shop safety training or do not feel confident about your knowledge of safe servicing practices, we recommend that you do not attempt to perform the procedures described in this manual.

Some of the most important general service safety precautions are given below. However, we cannot warn you of every conceivable hazard that can arise in performing service and repair procedures.

Only you can decide whether or not you should perform a given task.

### Important Safety Precautions

- Make sure you have a clear understanding of all basic shop safety practices and that you are wearing appropriate clothing and using safety equipment. When performing any service task, be especially careful of the following:
  - └ Read all of the instructions before you begin, and make sure you have the tools, the replacement or repair parts, and the skills required to perform the tasks safely and completely.
  - └ Protect your eyes by using proper safety glasses, goggles, or face shields any time you hammer, drill, grind, or work around pressurized air or liquids, springs, or other stored-energy components. If there is any doubt, put on eye protection.
  - └ Use other protective wear when necessary, for example, gloves or safety shoes. Handling hot or sharp parts can cause severe burns or cuts. Before you grab something that looks like it can hurt you, stop and put on gloves.
- Make sure the engine is off before you begin any servicing procedures, unless the instruction tells you to do otherwise. This will help eliminate several potential hazards:
  - └ Carbon monoxide poisoning from engine exhaust. Be sure there is adequate ventilation whenever you run the engine.
  - └ Burns from hot parts. Let the engine and exhaust system cool before working in those areas.
  - └ Injury from moving parts. If the instruction tells you to run the engine, be sure your hands, fingers, and clothing are out of the way.
- Gasoline vapors and hydrogen gasses from batteries are explosive. To reduce the possibility of a fire or explosion, be careful when working around gasoline or batteries.
  - └ Use only a nonflammable solvent, not gasoline, to clean parts.
  - └ Never drain or store gasoline in an open container.
  - └ Keep all cigarettes, sparks, and flames away from the battery and all fuel-related parts.

### ⚠ WARNING

Improper service or repairs can create an unsafe condition that can cause your customer or others to be seriously hurt or killed.

Follow the procedures and precautions in this manual and other service materials carefully.

### ⚠ WARNING

Failure to properly follow instructions and precautions can cause you to be seriously hurt or killed.

Follow the procedures and precautions in this manual carefully.

**EU2000i****INTRODUCTION**

This manual covers service and repair procedures for the Honda EU2000i generators. A supplement for the EU2000i Companion generator is located in the back of this manual.

All information contained in this manual is based on the latest product information available at the time of printing. We reserve the right to make changes at any time without notice.

No part of this publication may be reproduced, stored in a retrieval system, or transmitted, in any form by any means, electronic, mechanical, photocopying, recording, or otherwise, without prior written permission of the publisher. This includes text, figures, and tables.

As you read this manual, you will find information that is preceded by a **NOTICE** symbol. The purpose of this message is to help prevent damage to the generator, other property, or the environment.

**SAFETY MESSAGES**

Your safety and the safety of others are very important. To help you make informed decisions, we have provided safety messages and other safety information throughout this manual. Of course, it is not practical or possible to warn you about all the hazards associated with servicing these generators. You must use your own good judgement.

You will find important safety information in a variety of forms, including:

- **Safety Labels** – on the generator.
- **Safety Messages** – preceded by a safety alert symbol  and one of three signal words: DANGER, WARNING, or CAUTION.

These signal words mean:

** DANGER**

You **WILL** be KILLED or SERIOUSLY HURT if you don't follow instructions.

** WARNING**

You **CAN** be KILLED or SERIOUSLY HURT if you don't follow instructions.

** CAUTION**

You **CAN** be HURT if you don't follow instructions.

- **Instructions** – how to service these generators correctly and safely.

**American Honda Motor Co., Inc.  
Service Communications Department**

**CONTENTS**

<b>SPECIFICATIONS</b>	<b>1</b>
<b>SERVICE INFORMATION</b>	<b>2</b>
<b>MAINTENANCE</b>	<b>3</b>
<b>MUFFLER</b>	<b>4</b>
<b>AIR CLEANER/CARBURETOR</b>	<b>5</b>
<b>CONTROL PANEL</b>	<b>6</b>
<b>SIDE COVERS/FUEL TANK/ FRONT FRAMES/UNDER COVER</b>	<b>7</b>
<b>RECOIL STARTER/FAN COVER</b>	<b>8</b>
<b>GENERATOR</b>	<b>9</b>
<b>CAM PULLEY/CRANKSHAFT/ PISTON/CYLINDER BLOCK</b>	<b>10</b>
<b>OPERATION</b>	<b>11</b>
<b>SUPPLEMENT FOR COMPANION</b>	



# 1. SPECIFICATIONS

## EU2000i

1. SPECIFICATIONS.....	1-1	4. DIMENSIONAL DRAWINGS.....	1-4
2. CHARACTERISTICS .....	1-2	5. WIRING DIAGRAM .....	1-5
3. PERFORMANCE CURVES.....	1-3		

## 1. SPECIFICATIONS

### DIMENSIONS AND WEIGHTS

Model	EU2000i
Overall length	510 mm (20.1 in)
Overall width	290 mm (11.4 in)
Overall height	425 mm (16.7 in)
Dry weight	21.0 Kg (46.3 lb)
Operating weight	24.0 kg (53.0 lb)

### ENGINE

Model	GX100
Description code	GCANM
Type	4-stroke, overhead camshaft single cylinder
Displacement	98 cm <sup>3</sup> (5.98 cu in)
Bore x Stroke	56.0 x 40.0 mm (2.20 x 1.57 in)
Compression ratio	8.5 : 1
Cooling system	Forced air
Ignition system	Full transistor
Ignition timing	25° B.T.D.C.
Spark plug	NGK: CR5HSB
Carburetor	Float type, Horizontal, butterfly valve type
Air cleaner	Semi-dry type
Governor	Electronic control type
Lubrication system	Forced splash
Oil capacity	0.40 ℓ (0.42 US qt , 0.35 Imp qt)
Starting system	Recoil starter
Stopping system	Primary circuit ground
Fuel used	Automotive unleaded gasoline with a pump octane rating of 86 or higher

**GENERATOR**

Model	EU2000i
Description code	EAAJ
Generator type	Multipole field rotation type
Generator structure	Self-ventilation drip-proof type
Excitation	Self-excitation (Magnet type)
Voltage regulation system	PWM (Pulse width modulation)
Phase	Single phase
Rotating direction	Clockwise (viewed from the generator)
Frequency regulation	DC-AC conversion (Inverter type)

**2. CHARACTERISTICS**

Model	EU2000i	
Type	A	
Maximum output	2,000 VA	
Rated output	AC DC	1,600 VA 96 W
Rated frequency		60 Hz
Rated voltage	AC DC	120 V 12 V
Rated current	AC DC	13.3 A 8 A
Power factor		1.0 cos $\phi$
Voltage variation rate	Momentary Average Average time	10 % max. 6 % max. 3 sec. max
Voltage stability		$\pm 1$ %
Frequency variation rate	Momentary Average Average time	1 % max. 1 % max. 1 sec. max
Frequency stability		$\pm 0.1$ Hz
Insulation resistance		10 M $\Omega$ min.
AC circuit protector		18.7 A (Main circuit protector) 20 A (Branch circuit protector)
DC circuit protector		10 A
Fuel tank capacity		4.1 $\ell$ (1.08 US gal, 0.90 Imp gal)
Operating hours (at rated load without refueling)		Approx. 4.0 Hr *4.0 Hr
Noise level (at rated load)		59 dB (A) *59 dB (A)

\* Values indicate the specifications when the Eco-Throttle™ is OFF

## EU2000i

---

### 3. PERFORMANCE CURVES

The curves show performance of the generator under average conditions.

Performance may vary to some degree depending on ambient temperature and humidity.

The output voltage will be higher than usual when the generator is still cold, immediately after the engine starts.

#### AC EXTERNAL CHARACTERISTIC CURVES

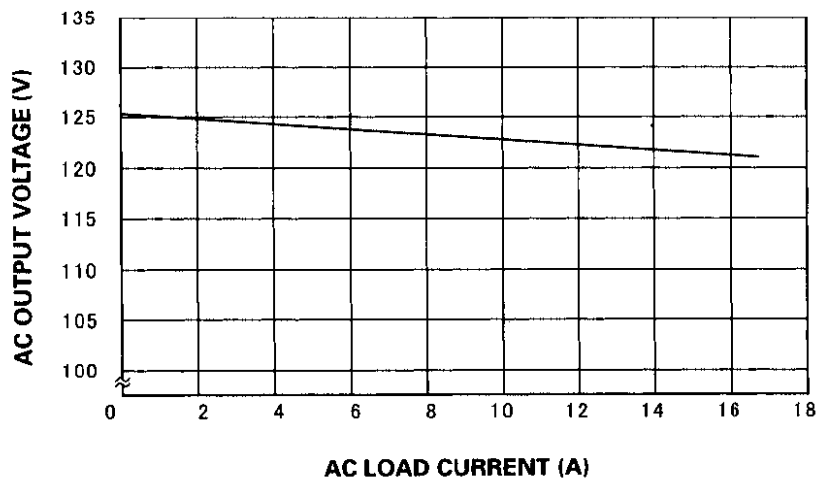

#### DC EXTERNAL CHARACTERISTIC CURVES

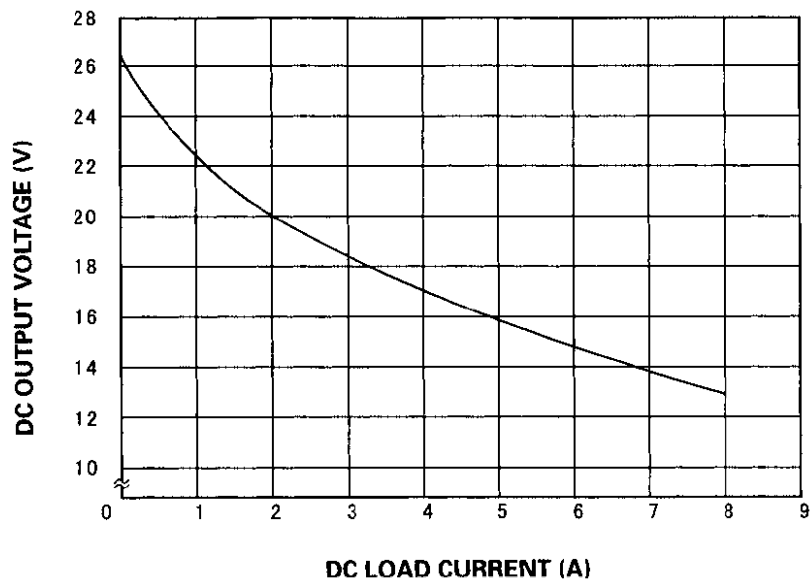

## 4. DIMENSIONAL DRAWING

Unit: mm (in)

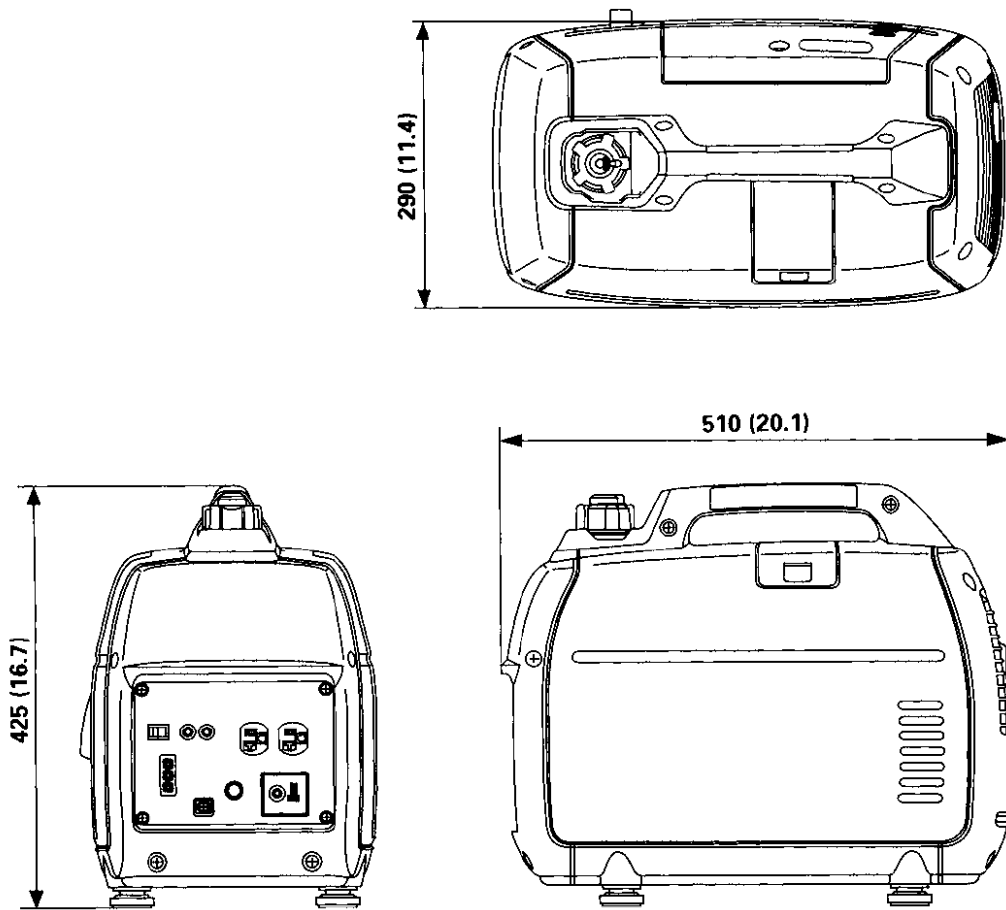

# EU2000i

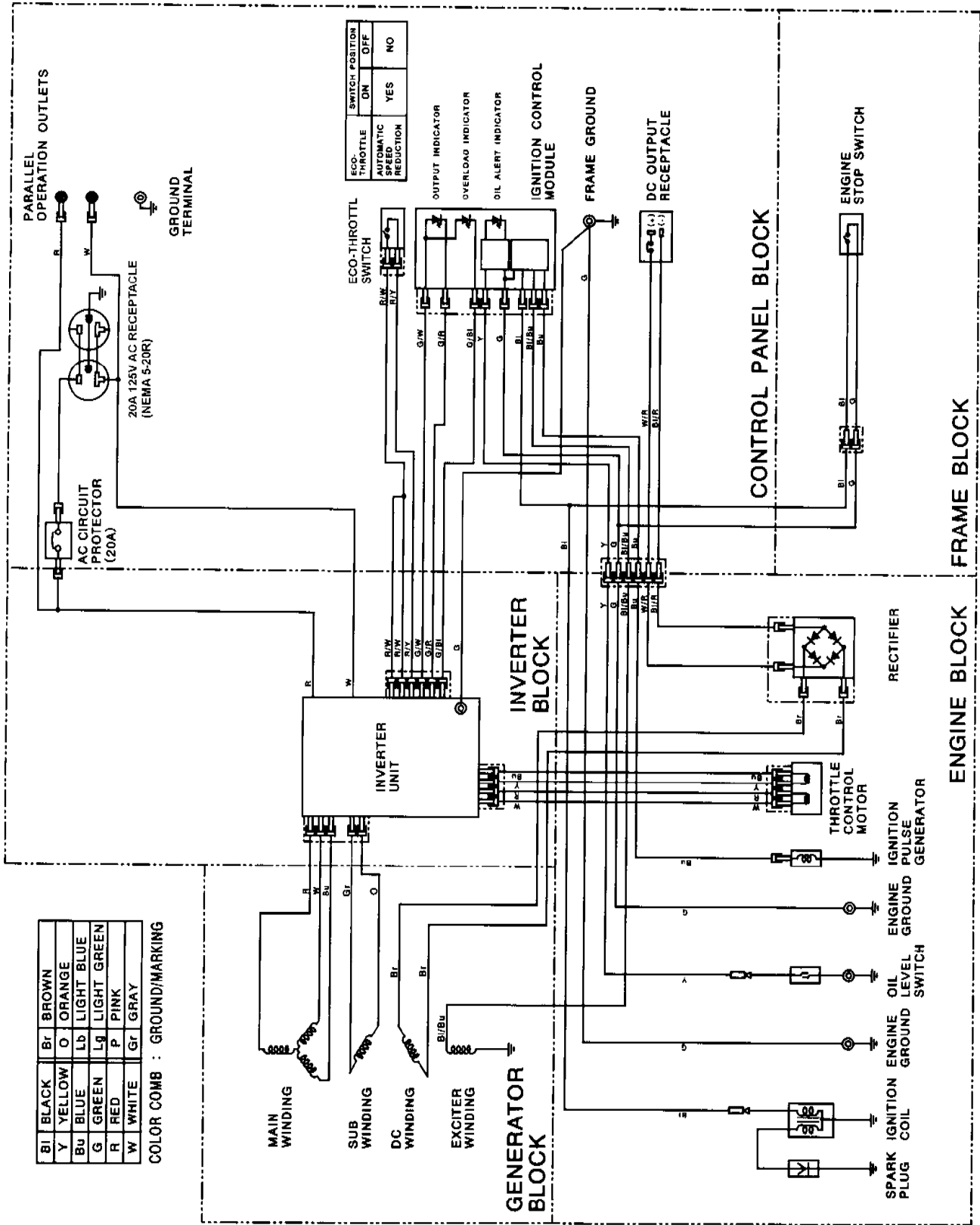







1. SYMBOLS USED IN THIS MANUAL.. 2-1	5. TORQUE VALUES .....2-5
2. SERIAL NUMBER LOCATIONS ..... 2-1	6. SPECIAL TOOLS.....2-6
3. ELECTRIC PRECAUTIONS..... 2-2	7. TROUBLESHOOTING .....2-7
4. MAINTENANCE STANDARDS..... 2-3	8. CABLE & HARNESS ROUTING .....2-20

## 1. SYMBOLS USED IN THIS MANUAL

As you read this manual, you may find the following symbols with the instructions.

 A special tool is required to perform the procedure.

 Apply grease.

 Apply oil.

○ x ○ (○): Indicates the diameter, length, and quantity of metric flange bolts used.

P.○—○ Indicates the reference page.

## 2. SERIAL NUMBER LOCATIONS

The frame serial number is shown at the underside of the right side cover, and the engine serial number is stamped on the cylinder block. Refer to these numbers when ordering or making technical inquiries.

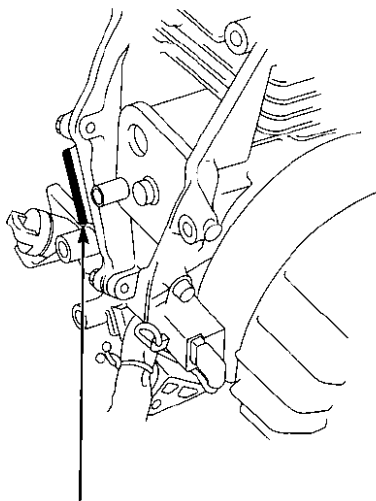

**ENGINE SERIAL NUMBER**

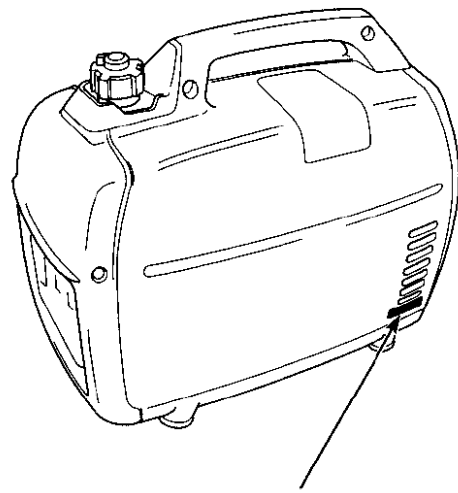

**FRAME SERIAL NUMBER**

### **3. ELECTRIC PRECAUTIONS**

1. Hold the connector body to disconnect the connector. Do not disconnect by pulling the wire harness. To disconnect the locking connector, be sure to unlock first, then disconnect.
  2. Check the connector terminals are not bend, damaged, or missing before connecting the connector.
  3. To connect, insert the connector as far as it goes. If the connector is a locking type, be sure that it is locked securely.
  4. Check the connector cover for breakage and check that the connector female terminal is not open excessively. Then, connect the connector securely. Check the connector terminal for rust. Remove the rust using emery paper or equivalent material before connecting the connector.
  5. Set the harness clips in the specified places of the frame securely, and secure the wire harnesses.
  6. Clamp the cables securely.
  7. Clamp the wire harnesses securely so that they do not interfere with the rotating parts, moving parts and the hot parts.
  8. Route and connect the wire harnesses properly. Be sure that the harnesses are not slack, twisted or pulled taut.
  9. Route the wire harnesses properly so that they do not contact with the sharp edges and corners, and the end of the bolts and screws on the body.
  10. If a wire harness contacts the end of the bolts/screws or sharp edges and corners, protect the contact part of the harness with a tube or by winding with electrician's protective tape. If the wire harness has a grommet, set the grommet securely.
  11. Take care not to pinch the wire harnesses during installation of a part. If a wire harness has damaged insulation, repair by winding with electrical insulating tape.
  12. Read the tester manufacturer's operation instructions carefully before using a tester. Follow the instructions in the Service Manual. Be sure that battery in the tester is fully charged, and check the meter before inspection using the tester.
-



Part	Item	Standard	Service limit
Spark plug	Gap	0.6 – 0.7 mm (0.024 – 0.028 in)	—
Ignition coil	Resistance	0.7 – 1.1 $\Omega$	—
	Primary side Secondary side	12 – 21 K $\Omega$	—
Ignition pulse generator	Air gap	0.2 – 0.7 mm (0.008 $\pm$ 0.028 in)	—
	Resistance	300 – 360 $\Omega$	—

**GENERATOR**

Part	Item	Standard	Service limit
Exciter coil	Resistance	Black/blue – green 0.2 – 0.3 $\Omega$	—
Sub coil	Resistance	Gray – orange 0.1 – 0.2 $\Omega$	—
DC coil	Resistance	Brown – brown 0.1 – 0.2 $\Omega$	—
AC coil	Resistance	Red – White 1.4 – 1.5 $\Omega$	—
		Red – blue 1.4 – 1.5 $\Omega$	—
		White – blue 1.4 – 1.5 $\Omega$	—

**EU2000i****5. TORQUE VALUES**

Item	Thread dia. x pitch	Tightening torque		
		N·m	kgf·m	lbf·ft
Spark plug	M10 x 1.0	12	1.2	8.7
Connecting rod bolt	M5 x 0.8	5	0.5	3.6
Valve adjusting lock nut	M5 x 0.5 (Special nut)	7.5	0.75	5.4
Air cleaner cover screw	M6 x 1.0	2.3	0.23	1.7
Rotor nut	12 mm	51	5.2	37.6
Maintenance cover screw	6 mm	2.3	0.23	1.7
Fuel pump self-tapping screw	5 mm	3.4	0.35	2.5
Fuel cock self-tapping screw	5 mm	3.4	0.35	2.5
Recoil starter rope guide self-tapping screw	5 mm	1.2	0.12	0.9
L. side cover self-tapping screw	5 mm	1.2	0.12	0.9
Control panel self-tapping screw	5 mm	1.4	0.14	1.0
Engine stop switch self-tapping screw	3 mm	0.5	0.05	0.4
Front cover screw	6 mm	4.4	0.45	3.3
Rear cover screw	6 mm	4.4	0.45	3.3
Carburetor insulator bolt	6 mm	7.8	0.8	5.8
Muffler bolt	6 mm	11.8	1.2	9
R. side cover underside bolt	6 mm	9.3	0.95	6.9

## NOTE:

- Use standard torque values for the fasteners that are not listed in this table.
- (CT) indicates a self-tapping bolt.
- (SH) indicates a small head bolt.

**STANDARD TORQUE**

Item	Thread dia. (mm)	Torque		
		N·m	kgf·m	lbf·ft
Screw	3 mm	1	0.1	0.7
	4 mm	1.1	0.11	0.8
	5 mm	4.3	0.43	3.1
	6 mm	9	0.9	6.5
Bolt and nut	5 mm	5	0.5	3.6
	6 mm	10	1.0	7
	8 mm	21	2.1	15
	10 mm	34	3.5	25
	12 mm	54	5.5	40
Flange bolt and nut	4 mm	3.4	0.35	2.5
	5 mm	5.5	0.55	4.0
	6 mm	12	1.2	9
	8 mm	26	2.7	20
	10 mm	39	4.0	29
SH flange bolt	6 mm	9	0.9	6.5
CT flange bolt	5 mm	5.5	0.55	4.0
	6 mm	12	1.2	9

## 6. SPECIAL TOOLS

No.	Tool name	Tool number	Application
1.	Float level gauge	07401-0010000	Carburetor float level inspection
2.	Driver, 22 mm I.D.	07746-0020100	Driver for 5
3.	Attachment, 32 x 35 mm	07746-0010100	20 x 32 x 6 mm oil seal installation
4.	Attachment, 42 x 47 mm	07746-0010300	6204 radial ball bearing installation
5.	Attachment, 20 mm I.D.	07746-0020400	6204 radial ball bearing installation
6.	Pilot, 20 mm	07746-0040500	20 x 32 x 6 mm oil seal and 6204 radial ball bearing installation
7.	Driver	07749-0010000	Driver for 3, 4 and 6
8.	Valve seat cutter, 45° 24.5 mm*	07780-0010100	Valve seat reconditioning (IN)
9.	Valve seat cutter, 45° 24 mm*	07780-0010600	Valve seat reconditioning (EX)
10.	Valve seat cutter, 32° 25 mm*	07780-0012000	Valve seat reconditioning (IN)
11.	Valve seat cutter, 32° 24 mm*	07780-0012500	Valve seat reconditioning (EX)
12.	Valve seat cutter, 60° 24 mm*	070PH-Z0D0100	Valve seat reconditioning (IN/EX)
13.	Valve adjuster wrench, 3 mm	07908-KE90200	Valve clearance adjustment
14.	Cutter holder, 4.0 x 400 mm*	070PH-Z0D0200	Valve seat reconditioning (IN/EX)
15.	Cleaning brush	07998-VA20100	Combustion chamber cleaning
16.	Valve guide driver, 3.6 x 8.0 mm	07JMD-KY20100	Valve guide removal/installation
17.	Valve guide reamer, 4.008 mm	07MMH-MV90100	Valve guide I.D. reaming
18.	Sliding hammer weight	07741-0010201	6204 radial ball bearing removal
19.	Bearing remover shaft handle	07936-3710100	6204 radial ball bearing removal
20.	Bearing remover shaft set 20	07936-3710600	6204 radial ball bearing removal

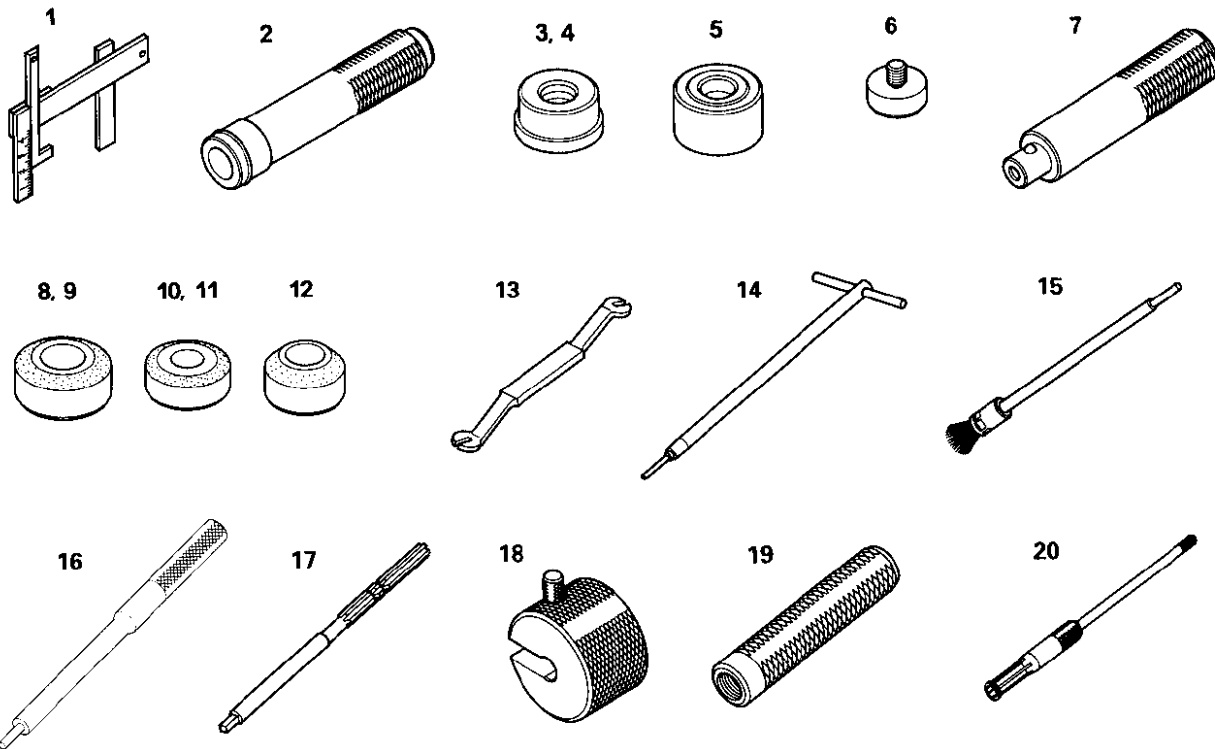

\*: Equivalent commercially available.

## EU2000i

## 7. TROUBLESHOOTING

## a. GENERAL SYMPTOMS AND POSSIBLE CAUSES

Engine does not start or hard starting.

**SERVICE BULLETIN #40 =>**

CARBURETOR FLOAT CHAMBER contains stale gasoline, or no fuel reaches the carburetor.

Drain old fuel and check and clean (P. 5-4).

FUEL TANK TUBE clogged.

Inspect (P. 3-7).

DIAPHRAGM TUBE disconnected.

Connect (P. 2-22).

FUEL FILTER clogged.

Clean (P. 3-7).

FUEL PUMP clogged.

Inspect (P. 3-7) and replace (P. 7-2).

CARBURETOR faulty.

Readjust (P. 5-5) and/or disassemble and clean (P. 5-4).

SPARK PLUG CAP disconnected.

Install securely.

IGNITION PULSE GENERATOR air gap incorrect.

Replace (P. 9-1).

IGNITION COIL faulty.

Inspect (P. 8-4) and replace (P. 8-1).

SPARK PLUG faulty.

Inspect and replace (P. 3-4).

ENGINE SWITCH faulty.

Inspect (P. 7-5) and replace (P. 7-4).

OIL LEVEL SWITCH faulty.

Inspect (P. 10-17) and replace (P. 10-14).

IGNITION CONTROL MODULE faulty.

Inspect (P. 6-4) and replace (P. 6-2).

IGNITION PULSE GENERATOR faulty.

Inspect (P. 9-3) and replace (P. 9-1).

EXCITER COIL faulty.

Inspect (P. 9-3).

VALVE CLEARANCE incorrect.

Adjust (P. 3-5).

THROTTLE VALVE set in fully closed position when reassembling.

Set in fully open position.



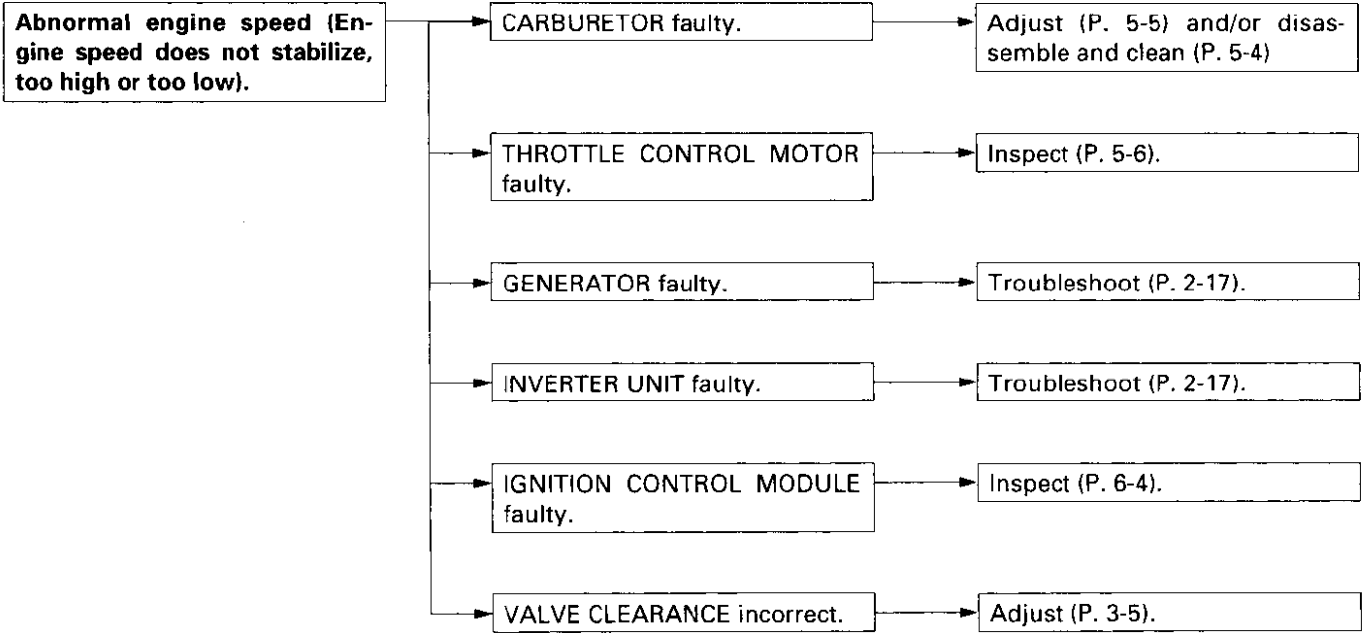

**EU2000i**

**b. ENGINE**

**SERVICE BULLETIN #40 =>**

**• Hard Starting**

If the engine does not start or is hard starting after reassembly, check to see whether the throttle valve is at the full open position.

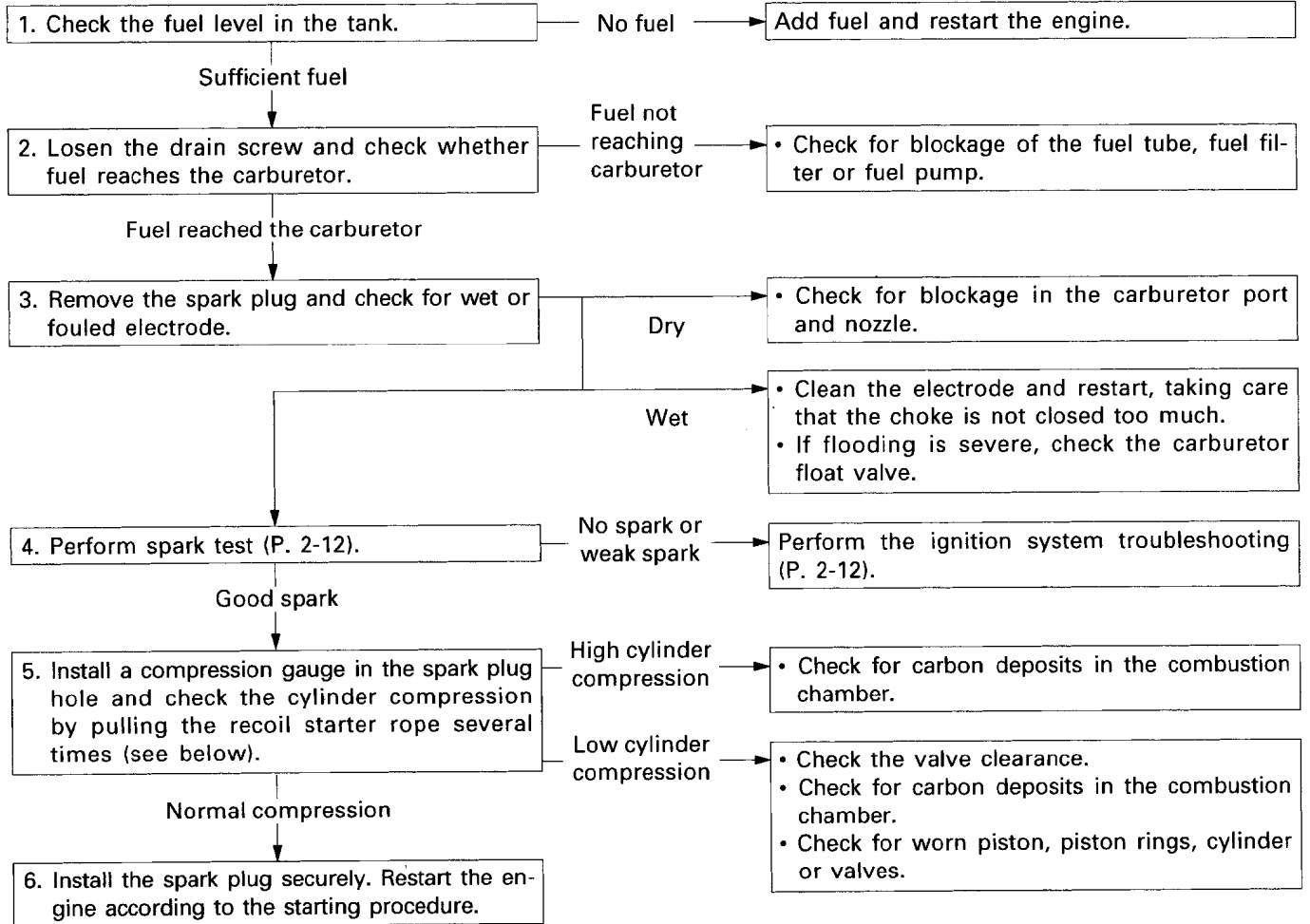

**• CYLINDER COMPRESSION CHECK**

- 1) Remove the spark plug cap and the spark plug, and install a compression gauge in the spark plug hole.
- 2) Pull the recoil starter rope forcefully several times, and measure the cylinder compression.

Cylinder compression	0.49 MPa (5.0 kgf/cm <sup>2</sup> , 71 psi) at 700 min <sup>-1</sup> (rpm)
----------------------	--

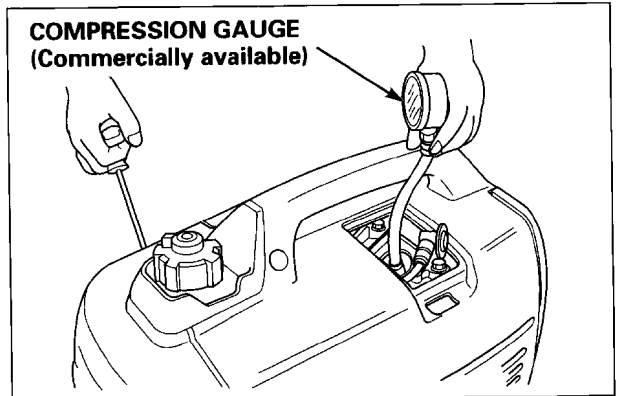

### • Engine Starts but Then Stalls

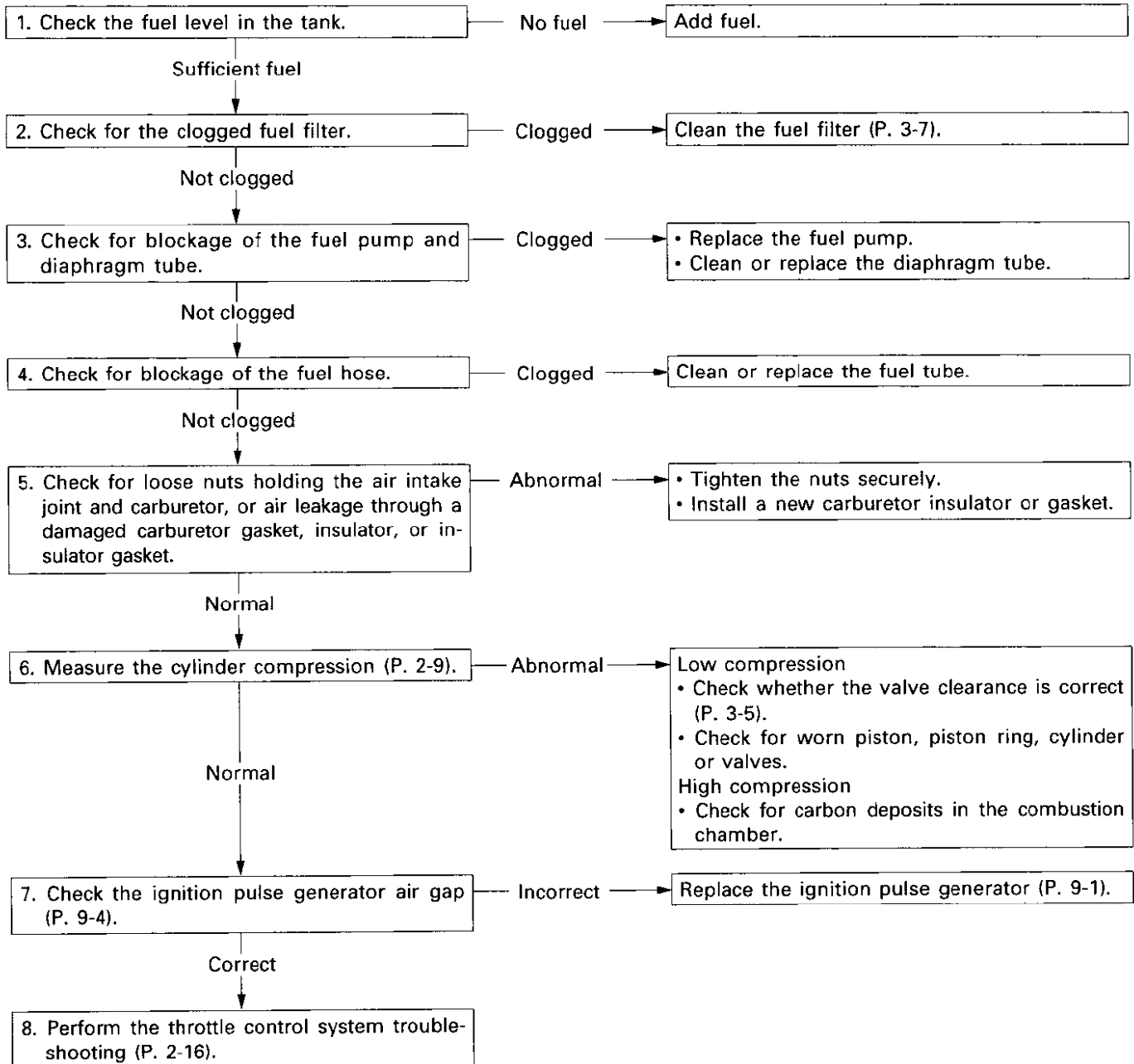

**SERVICE BULLETIN #41 =>**

**EU2000i**

**• Engine Speed Does Not Increase or Stabilize.**

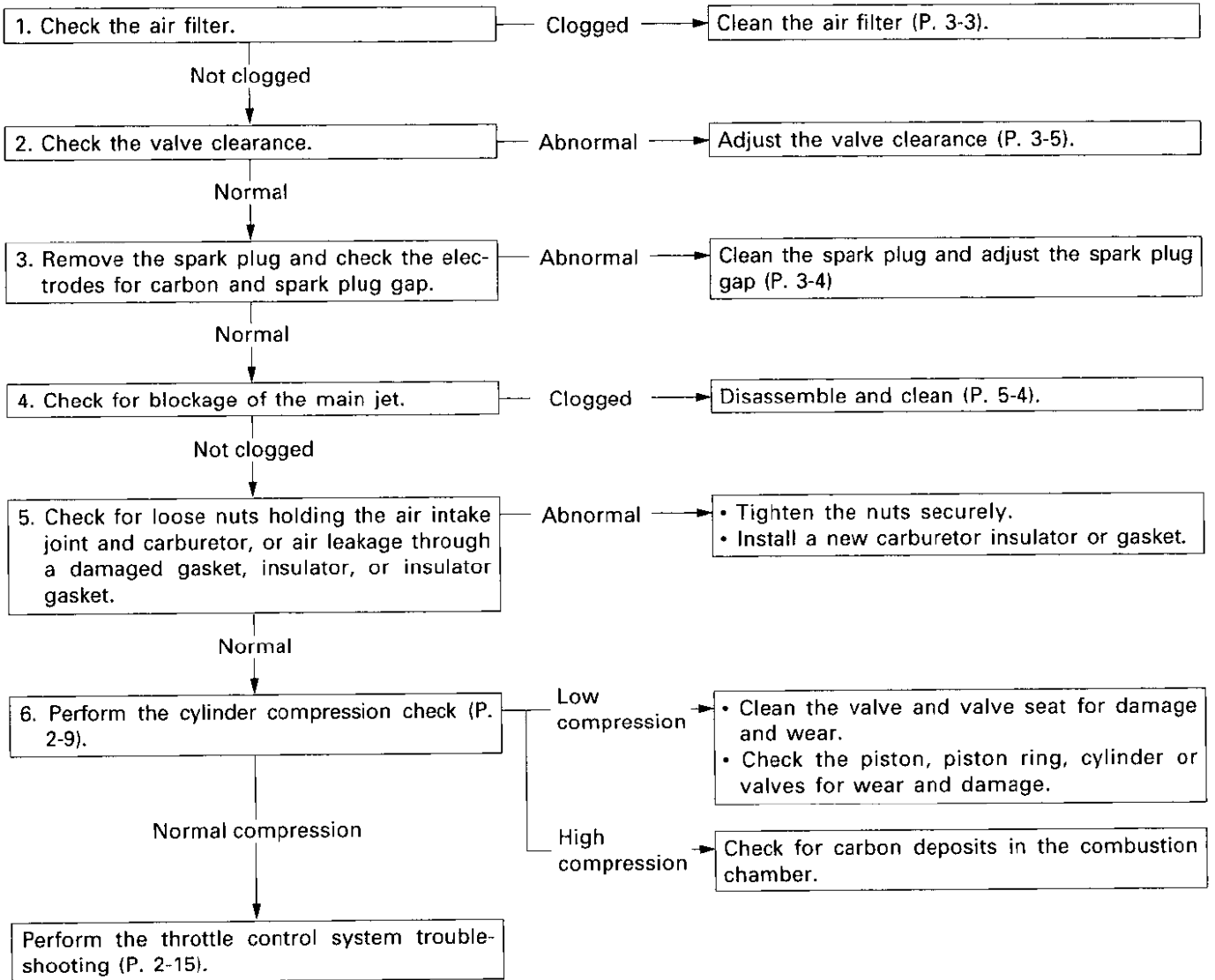

### c. IGNITION SYSTEM

NEW

Make a copy of the EU2000i Ignition System Troubleshooting Worksheet (P. 2-13b) and document your test results for future reference or in case you need to call Techline.

#### ⚠WARNING

Gasoline is highly flammable and explosive.

If ignited, gasoline can burn you severely.

Be sure there is no spilled fuel near the engine before performing this test.

1. Turn the engine stop switch to the ON position and pull the starter grip. Verify the Oil Alert® indicator is not flashing.

If flashing, add oil to bring the level to the upper limit.

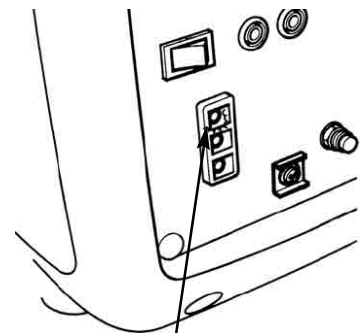

OIL ALERT® INDICATOR

2. Remove the maintenance cover.
3. Clamp the carburetor inlet fuel line and drain the carburetor float bowl.
4. Remove the air cleaner case (P. 5-1).

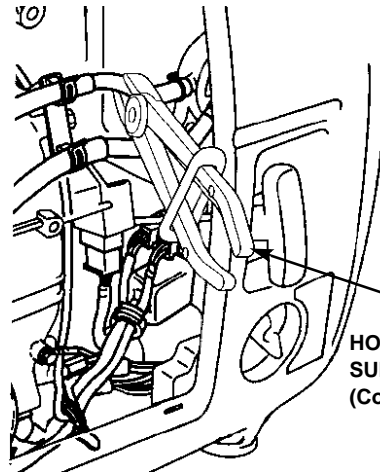
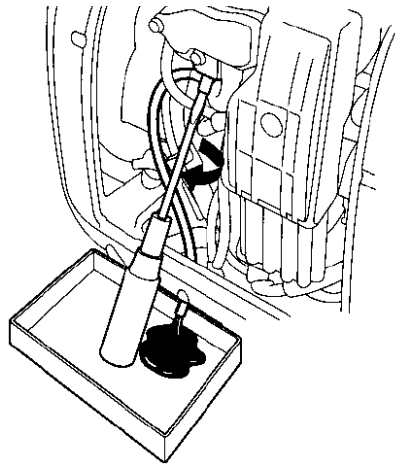

HOSE PINCHING PLIERS,  
SUN-HCP6  
(Commercially available)

5. Remove the spark plug and pull the starter grip several times to remove any unburned fuel from the combustion chamber.
6. Insert the spark plug into the spark plug boot.
7. Set the ignition switch to the ON position.
8. Ground the negative (-) electrode (threaded part) of the spark plug against the shroud.
9. Pull the starter grip and check for spark at the spark plug.

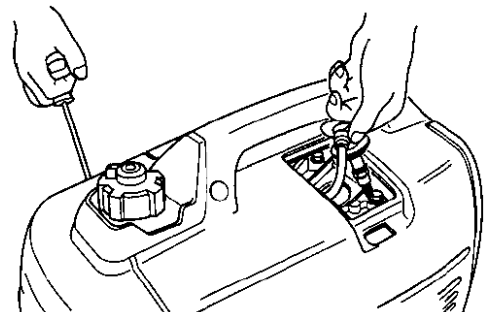

## EU2000i

If there is no spark at the spark plug, replace the spark plug with a new one and recheck for spark.

10. Disconnect the engine stop switch 2-pin connector and recheck for spark.

There should be spark with the switch disconnected.

- If there is spark, replace the engine stop switch and retest for spark.
- If there is no spark, document your results and continue.

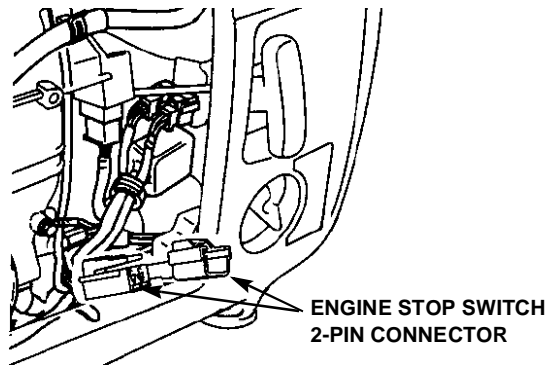

11. Disconnect the 6-pin connector.

12. Test the oil level switch. Make sure the oil level in the engine is correct and the generator is on a level surface. On the engine side of the 6-pin connector, check for continuity between the yellow wire and green wire.

There should be no continuity with the proper oil level.

Document your results and continue.

ENGINE SIDE 6-PIN CONNECTOR

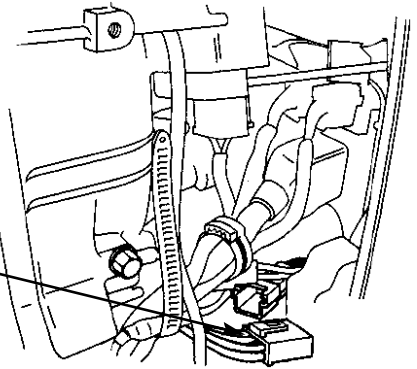
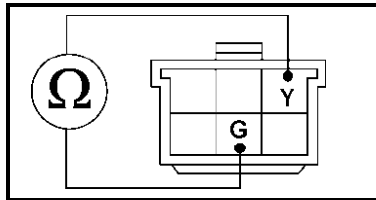

13. Measure the resistance of the ignition pulse generator (IPG).

On the engine side of the 6-pin connector, test between the blue wire and green wire.

**Specification: 300 ~ 360  $\Omega$**

Document your results and continue.

ENGINE SIDE 6-PIN CONNECTOR

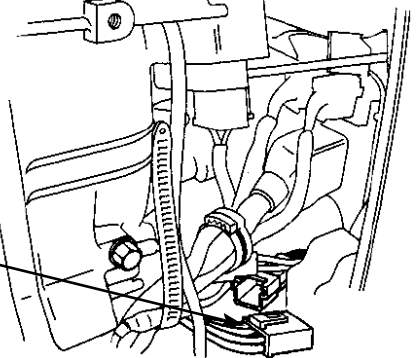
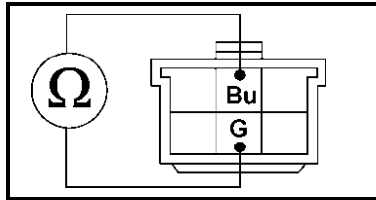

14. Measure the DC millivolt output of the ignition pulse generator (IPG).

On the engine side of the 6-pin connector, test between the blue wire and green wire and pull the starter grip.

**Specification: 3 ~ 4 mV DC**

Document your results and continue.

ENGINE SIDE 6-PIN CONNECTOR

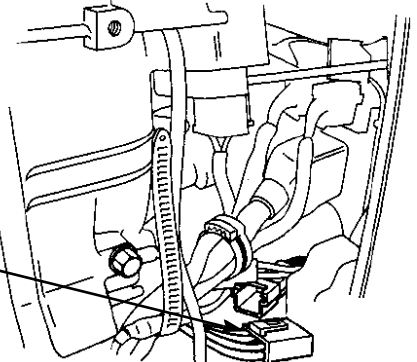
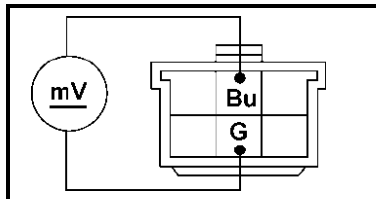

NEW

NEW

NEW

NEW

NEW

15. Measure the resistance of the exciter winding.

On the engine side of the 6-pin connector, test between the black/blue wire and green wire.

**Specification: 0.2 ~ 0.3  $\Omega$**

Document your results and continue.

If the exciter winding measures a little over the specification, it may not need to be replaced. Additional resistance of 0.4 ~ 0.5 ohms will not cause a no-spark condition.

ENGINE SIDE 6-PIN CONNECTOR

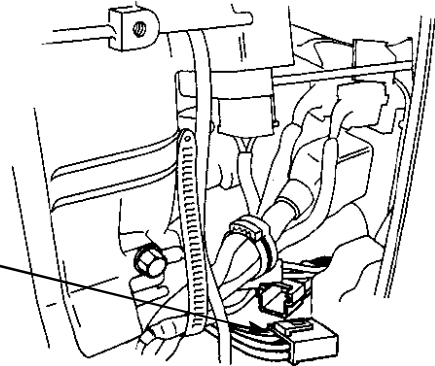
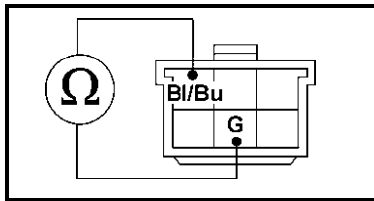

NEW

16. Measure the AC voltage output of the exciter winding.

On the engine side of the 6-pin connector, test between the black/blue wire and green wire and pull the starter grip.

**Specification: 4 ~ 5 VAC**

Document your results and continue.

ENGINE SIDE 6-PIN CONNECTOR

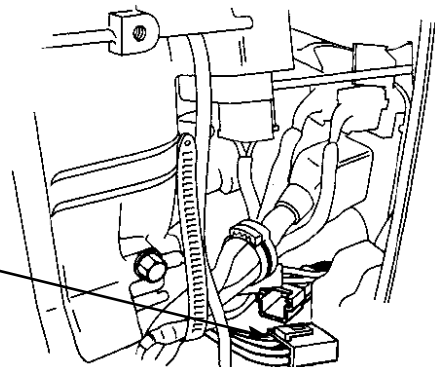
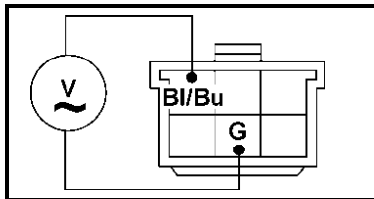

NEW

17. Measure the ignition coil resistance.

Disconnect the black bullet connector.

*Primary winding:* on the engine side of the connectors, measure between the black single bullet connector and the green wire of the 6-pin connector.

Document your results and continue.

**Specification: 0.7 ~ 1.1  $\Omega$**

If the ignition coil measures a little over the specification, it may not need to be replaced. Additional resistance of 0.4 ~ 0.5 ohms will not cause a no-spark condition.

*Secondary winding:* on the engine side of the connector, measure between the green wire of the 6-pin connector and the spark plug cap.

**Specification: 12 K ~ 21 K $\Omega$**

Document your results and continue.

ENGINE SIDE 6-PIN CONNECTOR AND BLACK BULLET CONNECTOR

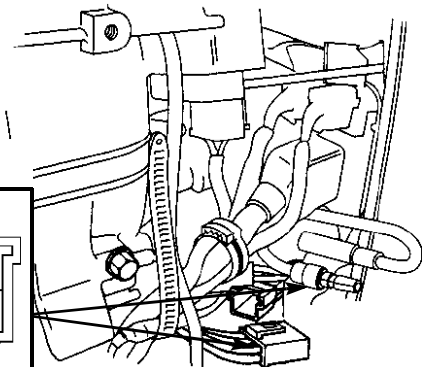
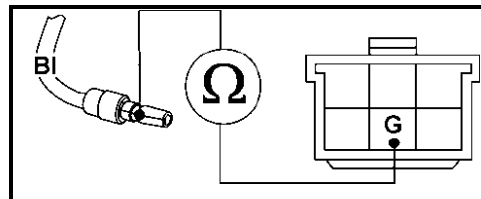

ENGINE SIDE 6-PIN CONNECTOR AND SPARK PLUG CAP

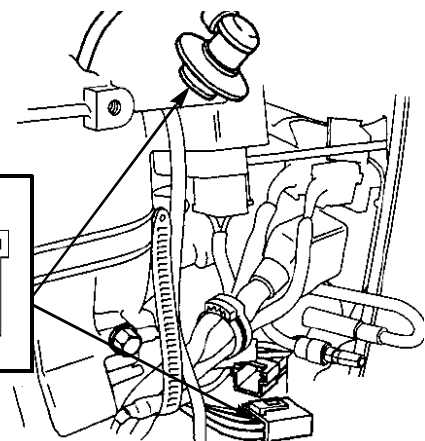
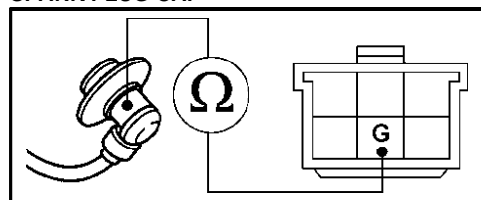

## EU2000i

18. Remove the control panel 5 x 16 mm self-tapping screws to access the wires behind it. Inspect the ignition control module (ICM) pins and ICM wire harness connector for loose, dirty, or corroded connections.

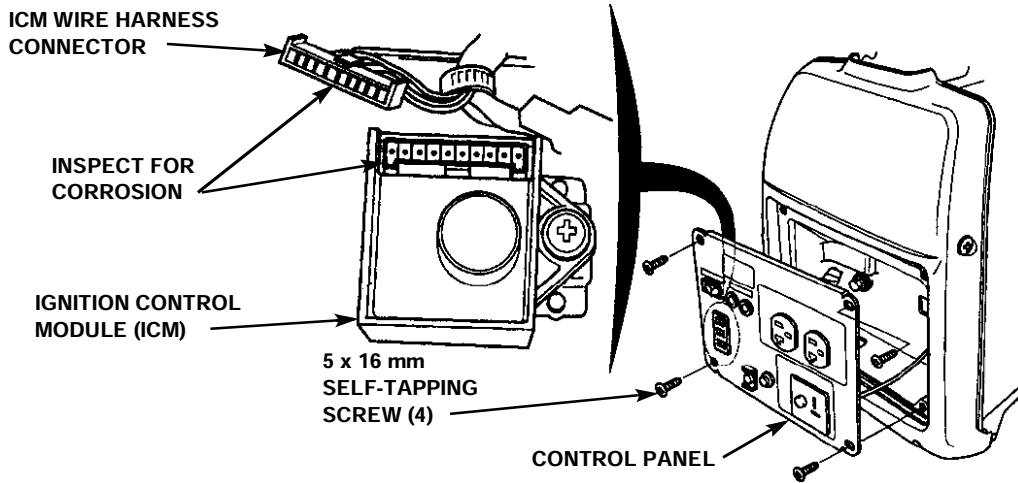

Green colored deposits on the pins or terminals are an indication of corrosion.

- If corrosion is present on the ICM pins or the ICM wire harness, replace the ICM and wire harness and recheck for spark.
- If the ICM and ICM wire harness are OK, go to the conclusion.

### CONCLUSION

- If all components passed the tests, replace the ignition control module and recheck for spark.
- If the engine stop switch, oil level switch, or ignition coil do not pass the tests, replace the failed component and recheck for spark.
- If the exciter fails EITHER test, replace the stator.

Replacing the stator under warranty requires PRIOR authorization.

- If the ignition pulse generator (IPG) fails BOTH tests, replace the IPG and recheck for spark.

If you are unsure of the necessary repair, contact Techline with your completed test record results for guidance.

### EU2000i IGNITION SYSTEM TROUBLESHOOTING WORKSHEET

COMPONENT	SPECIFICATION	YOUR RESULTS	PASS	FAIL
Engine Stop Switch	There should be spark with the switch disconnected			
Oil Level Switch	No continuity with the proper oil level			
IPG Resistance	300 ~ 360 $\Omega$			
IPG DC millivolts	3.0 ~ 4.0 mV DC			
Exciter Resistance	0.2 - 0.3 $\Omega$			
Exciter Voltage	4 - 5 VAC			
Ignition Coil Primary Resistance	0.7 ~ 1.1 $\Omega$			
Ignition Coil Secondary Resistance	12 ~ 21 K $\Omega$			
ICM and Harness Inspection	Inspect for loose, dirty, or corroded connections			



• **Engine Oil Level is Low, but Engine Does Not Stop.**

1. Drain the engine oil. Pull the recoil starter grip and check the Oil Alert® indicator light on the control panel.

No light

Remove the maintenance cover and the air cleaner (P. 5-1). Disconnect the 6P generator module connector (small) from the inverter. Check for continuity between the yellow wire of the connector and the ground terminal on the fan cover.

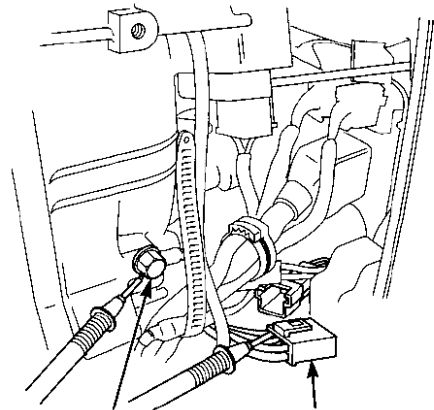

**GROUND TERMINAL**

**6P GENERATOR MODULE CONNECTOR**

**6P GENERATOR MODULE CONNECTOR**

Bl/Bu	Bu	Y
W/R	G	Bl/R

Lights

Continuity

No continuity

Replace the oil level switch (P. 10-14).

Perform the spark test again. Replace the ignition control module, if there is spark.

Repair or replace the wire harnesses.

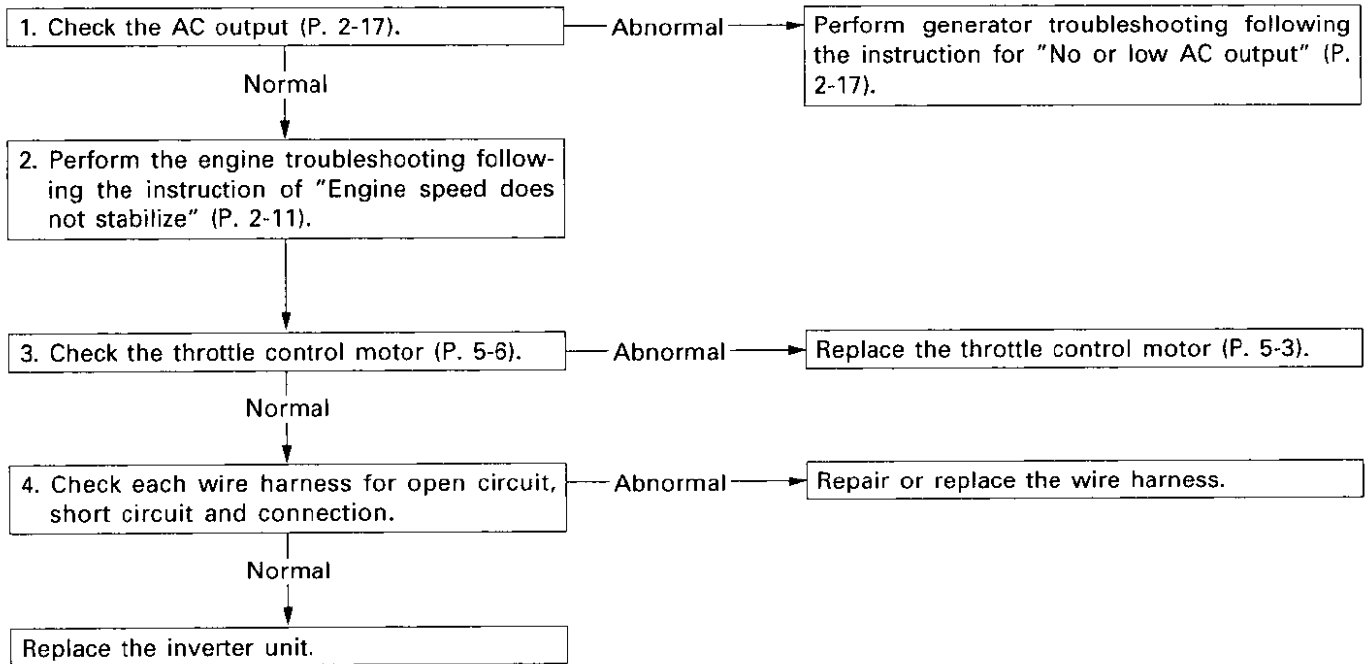
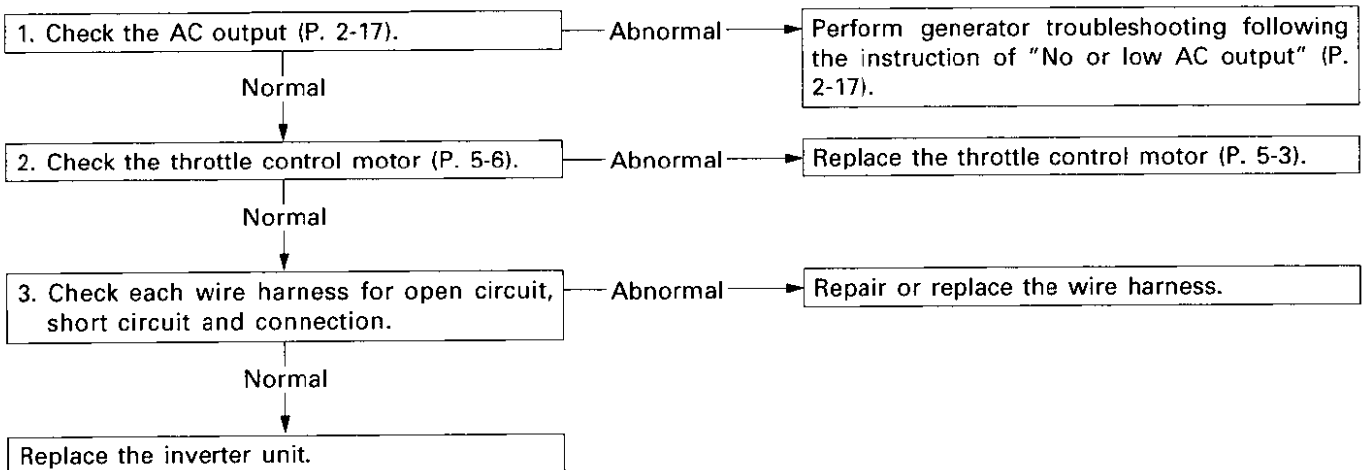
**EU2000i****d. THROTTLE CONTROL SYSTEM****SERVICE BULLETIN #41 =>****• Engine Speed is Too High, Unstable.****• Engine Speed Too Low.**

- **Engine Speed Does Not Increase With ECO Throttle System OFF Under No Load.**
- **Engine Speed Does Not Decrease With ECO Throttle System ON Under No Load.**
- **Engine Speed Does Not Increase by Connecting Load With ECO Throttle System ON.**

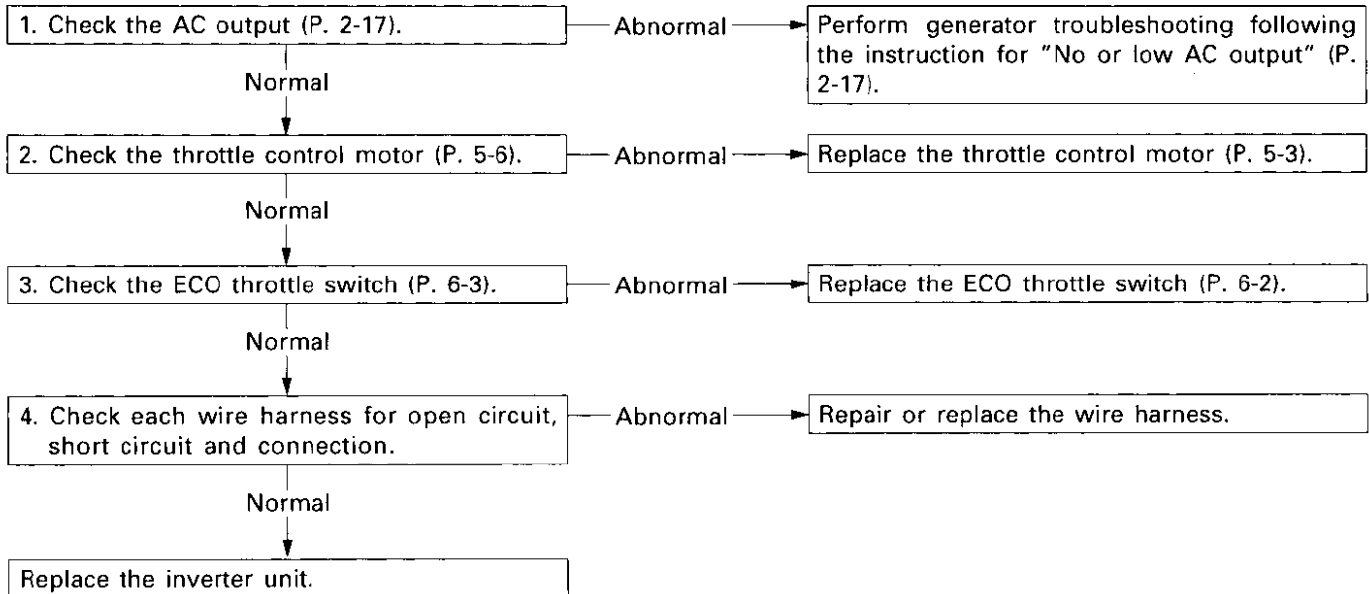

# EU2000i

## e. GENERATOR

**SERVICE BULLETIN #34 =>**

### • No or low AC output

#### **WARNING**

High voltage and electrical current present. Touching the non-insulated portions of the meter leads or generator wiring can cause shock or electrocution.

Wear insulated gloves and avoid handling non-insulated wiring.

Use a load bank (available through the Honda Tool and Equipment Program or the Parts Division) to verify the customer's initial complaint and the generator's performance after the repairs (see page 5-2 of the Generator Troubleshooting manual).

COMPLAINT: Abnormal output (none, low, or high) at the AC receptacle. **Normal AC output:** 120 VAC ± 18.

1. With the engine running, check the overload indicator light is OFF and the AC circuit protector is ON.
2. Check the AC output indicator light. If ON, inspect the AC receptacle or wiring to the receptacle. If OFF, proceed below.
3. Remove the maintenance cover.

4. Disconnect the 6-pin connector. With the 6-pin connector disconnected, the Eco-Throttle will not operate.

5. Manually set the rpm by moving the throttle lever with your finger. **Standard no-load speed: 4,200 – 4,600 rpm.**

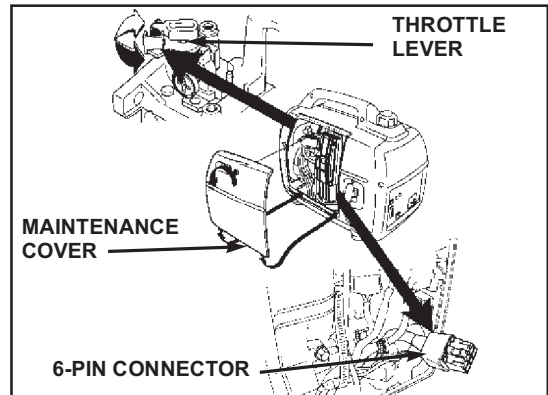

OK

NG

See *Engine Speed Does Not Increase or Stabilize* (P. 2-11).

6. Test output of each winding.	Color/test points (#)	Specified voltages
AC Winding	Red (1), Blue (2) Blue (2) White (3) Red (1), White (3)	225 VAC ± 18
Sub Winding	Orange (4), Gray(5)	12 VAC ± 4

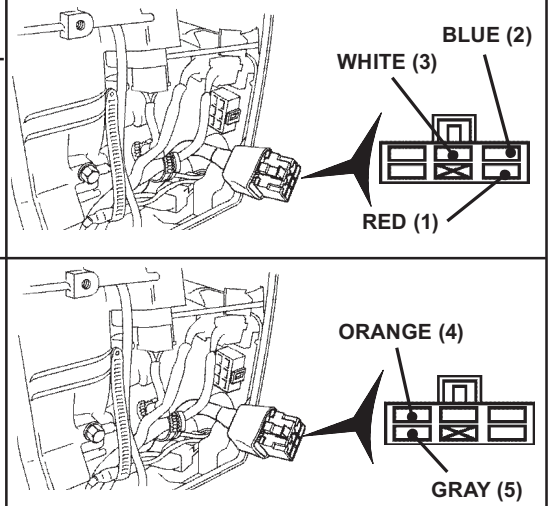

One or more windings test LOW or NO.

All windings test equally LOW

OK

7. Stator winding(s) faulty. Replace the stator. Call Techline.

Rotor magnet(s) weak. Replace the rotor. Call Techline.

Stop the engine.

Inspect the receptacle. Replace as necessary.

Reassemble the generator. Proceed to step 8.

Reassemble the generator. Proceed to step 8.

OK

Replace the inverter. Call Techline. Reassemble the generator. Proceed to step 8.

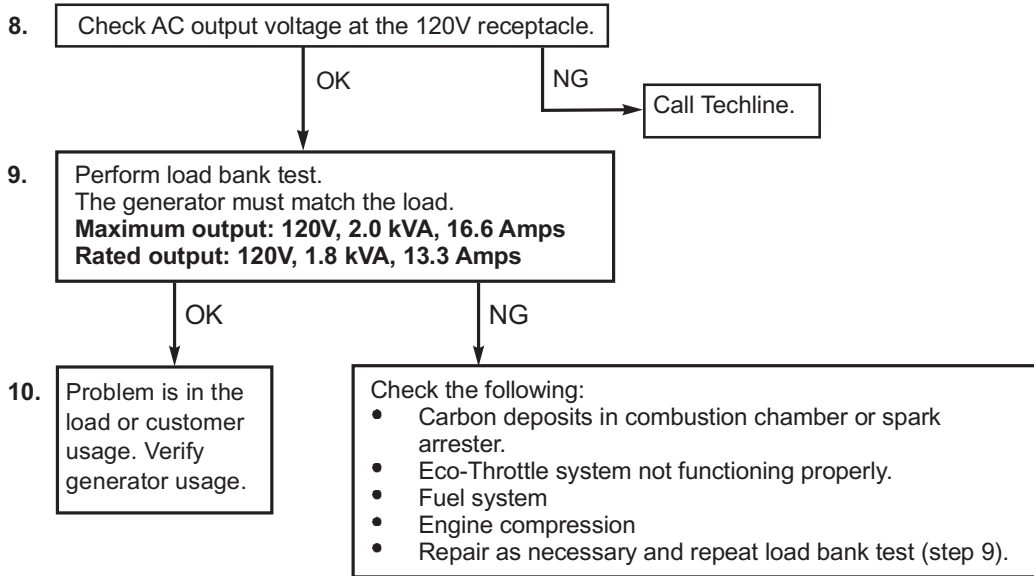

**GENERATOR TEST POINTS**

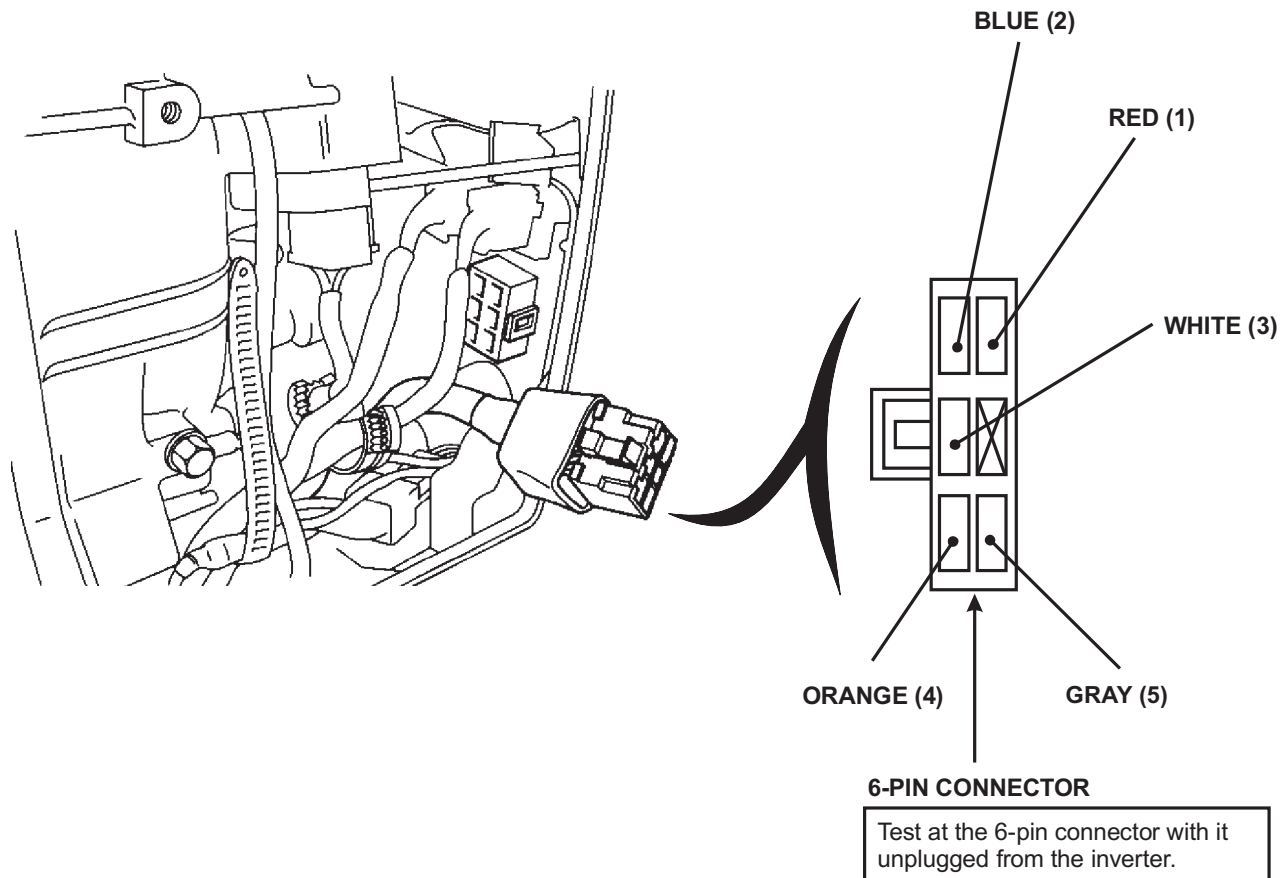

## EU2000i

### • No or low DC output

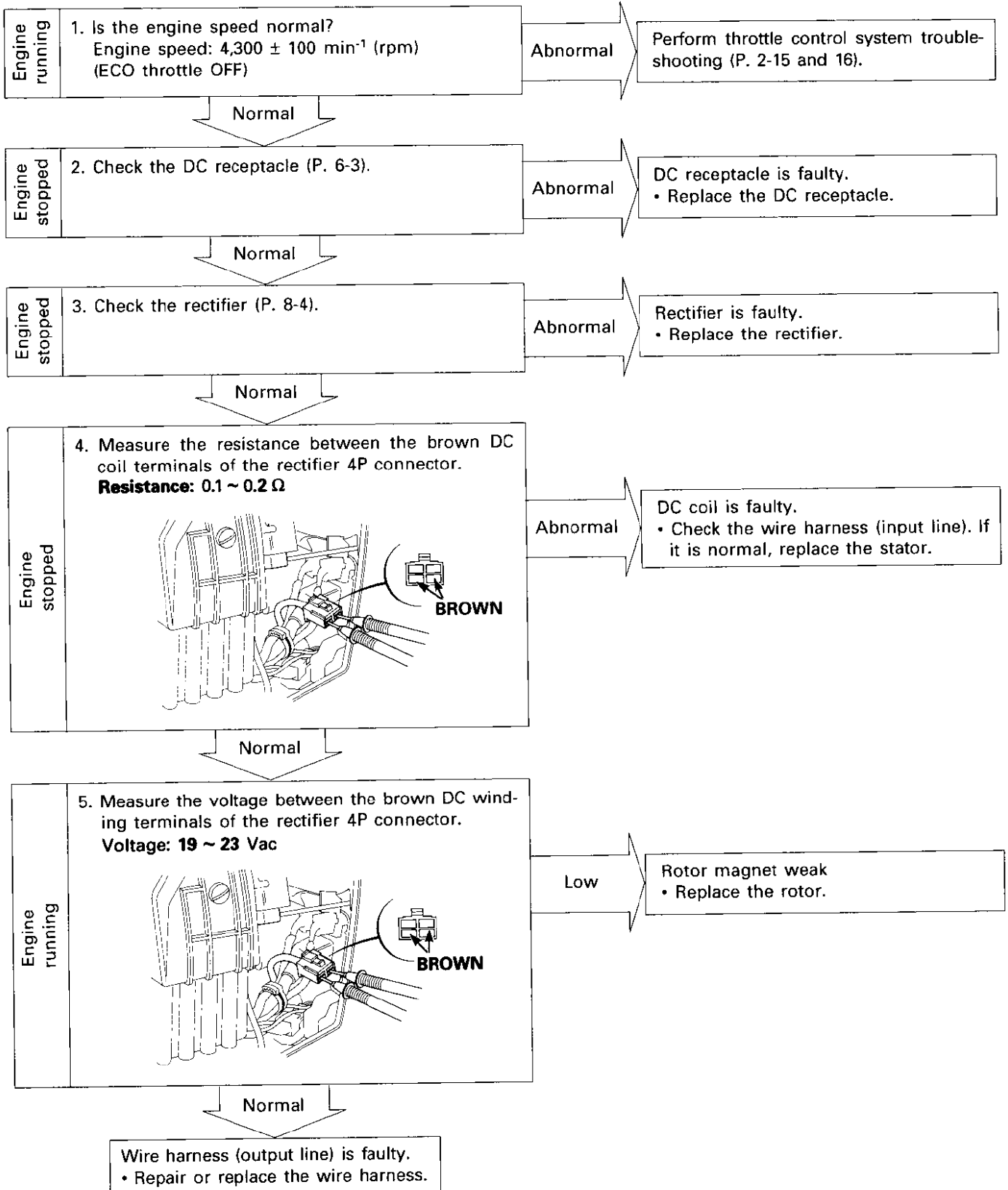

## 8. CABLE & HARNESS ROUTING

### • WIRE HARNESSES

#### OIL LEVEL SWITCH GROUND TERMINAL

**INSTALLATION:**  
Install noting the installation  
direction shown.

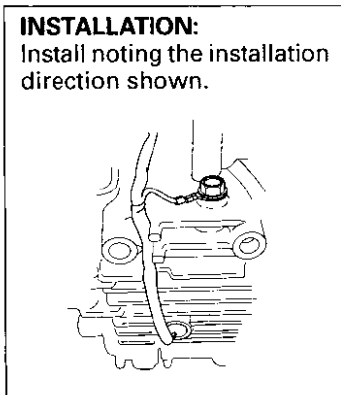

#### PURSE LOCK CLIP

**INSTALLATION:**  
Clamp the generator har-  
ness and oil level switch yel-  
low wire at terminal part.

#### OIL LEVEL SWITCH WIRE

#### GENERATOR HARNESS

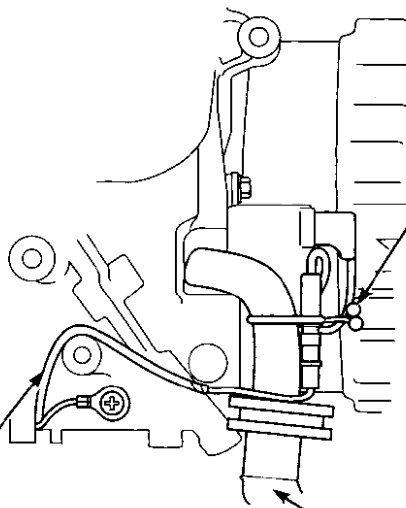

#### IGNITION COIL PRIMARY WIRE

**INSTALLATION:**  
Route the wire under the ig-  
nition coil and the rectifier  
and set in the grooves as  
shown.

#### IGNITION COIL

#### INVERTER UNIT

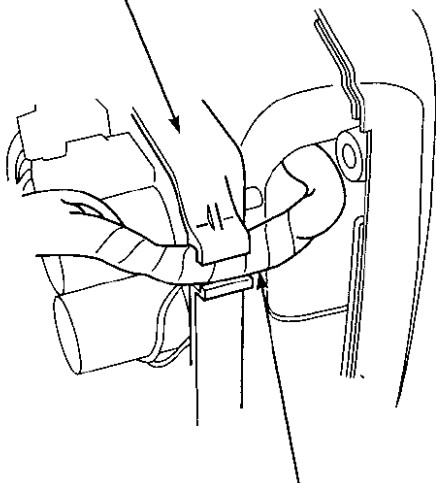

#### CONTROL WIRE HARNESS

**INSTALLATION:**  
Set the wire harness in the  
guide on the underside of  
the inverter unit securely.

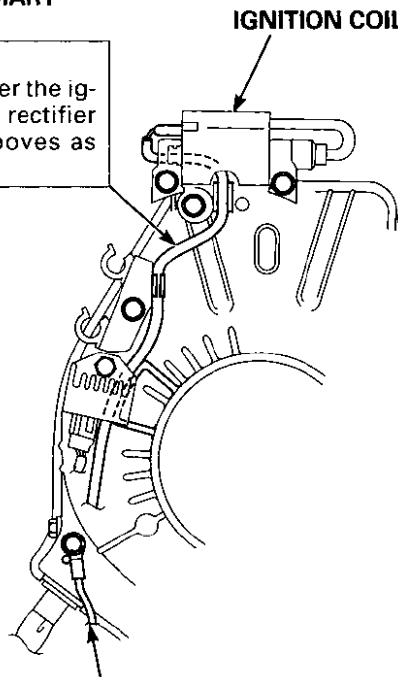

#### GENERATOR HARNESS GROUND WIRE

**INSTALLATION:**  
Tighten the terminal push-  
ing against the boss.

# EU2000i

## ● CONTROL PANEL

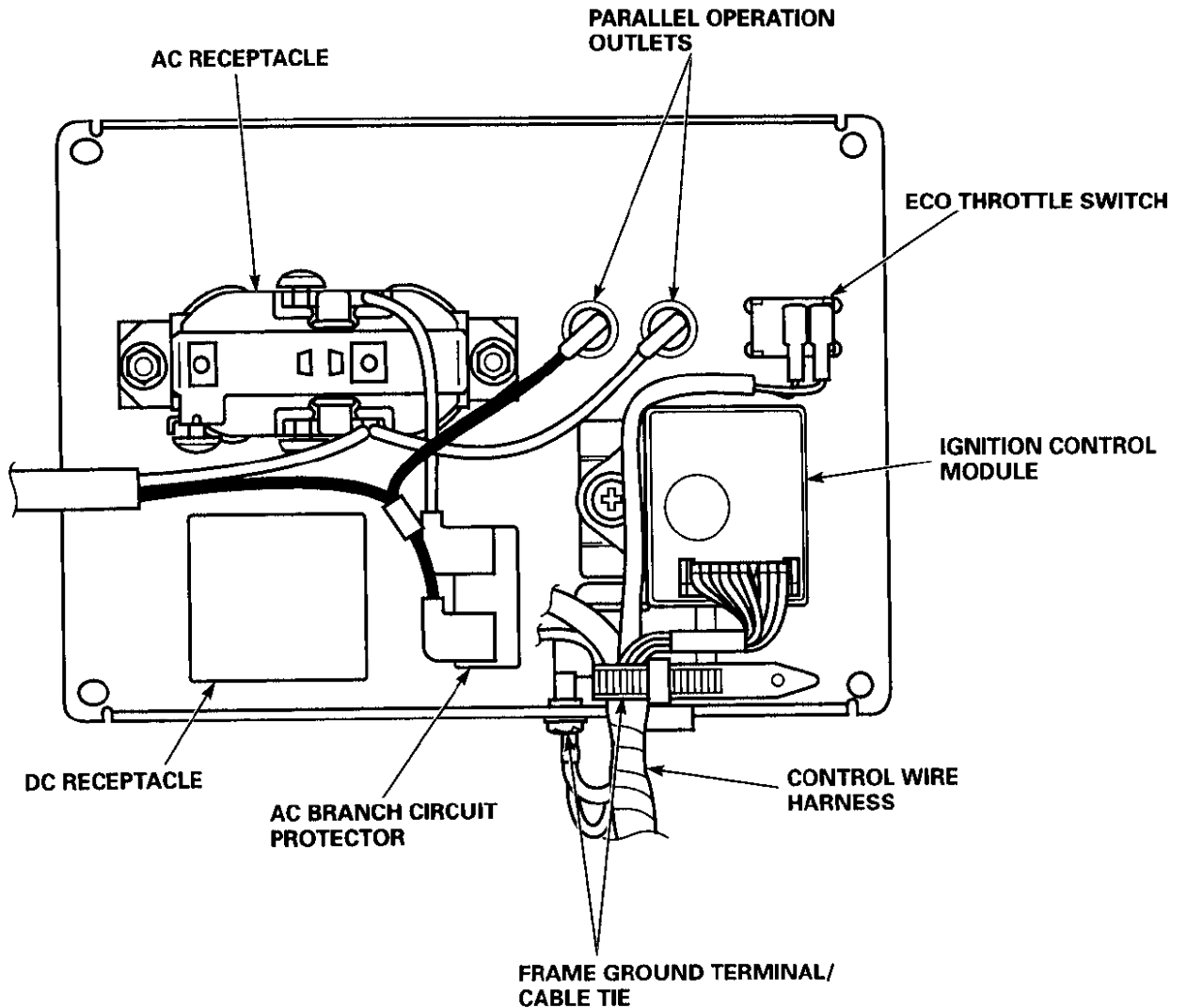

FRAME GROUND TERMINAL/  
CABLE TIE

**INSTALLATION:**

Install noting the installation direction shown.

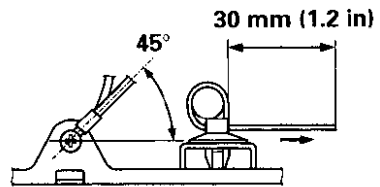



• TUBES

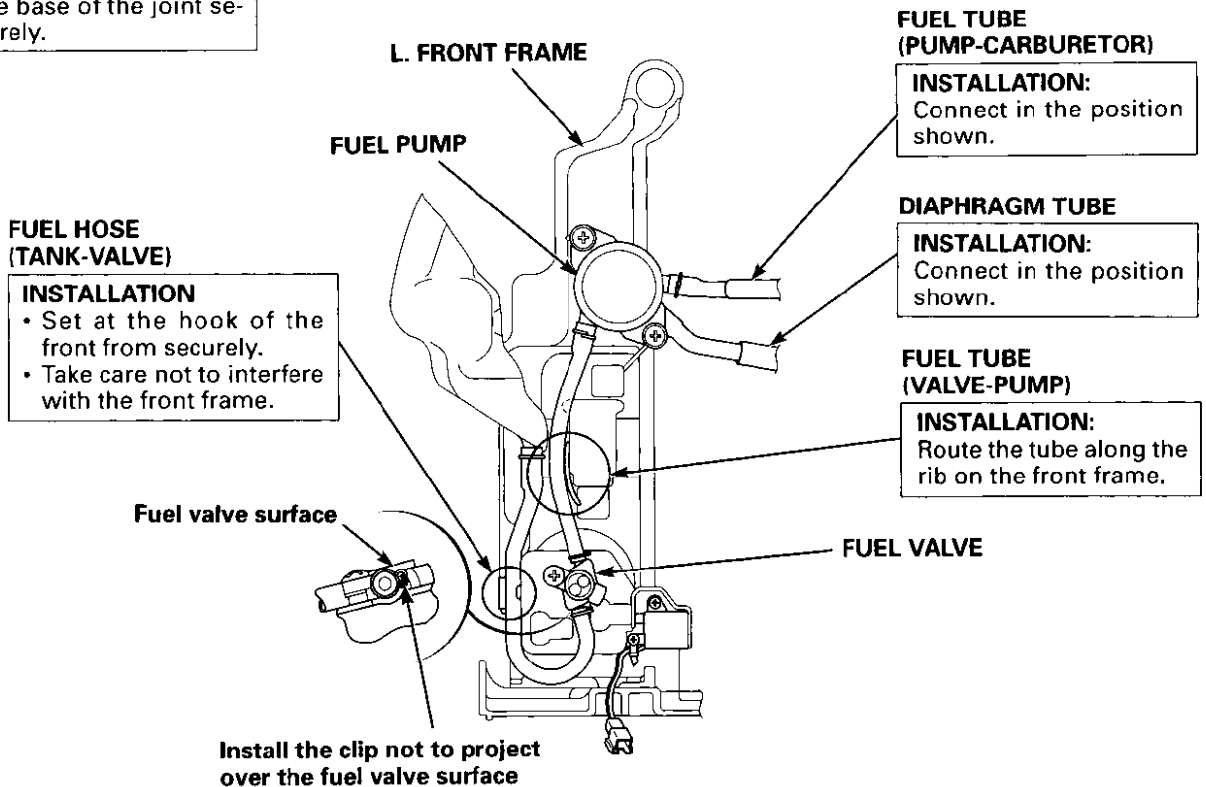
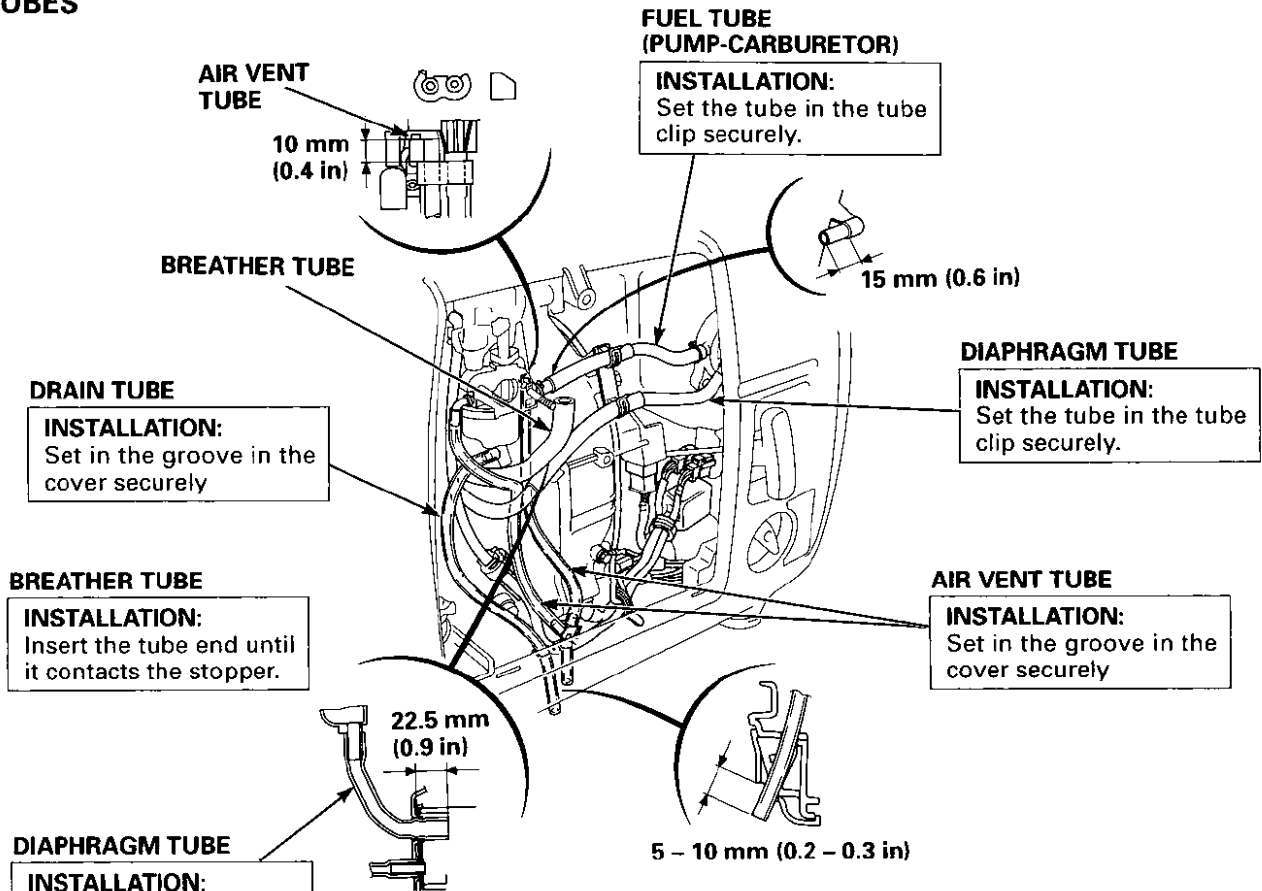

# 3. MAINTENANCE

## EU2000i

1. MAINTENANCE SCHEDULE .....	3-1	6. VALVE CLEARANCE .....	3-5
2. OIL ALERT .....	3-2	7. FUEL TANK/FUEL FILTER.....	3-7
3. ENGINE OIL .....	3-2	8. FUEL TUBE/FUEL PUMP DIAPHRAGM TUBE.....	3-7
4. AIR CLEANER .....	3-3	9. SPARK ARRESTER .....	3-8
5. SPARK PLUG .....	3-4		

## 1. MAINTENANCE SCHEDULE

REGULAR SERVICE PERIOD (1)		Each Use	First month or 20 Hrs	Every 3 months or 50 Hrs	Every 6 months or 100 Hrs	Every year or 200 Hrs	Ref. page
ITEM	Perform at every indicated month or operating hour interval, whichever comes first.						
● Engine oil	Check level	<input type="radio"/>					3-2
	Change		<input type="radio"/>		<input type="radio"/>		
● Air cleaner	Check	<input type="radio"/>					3-3
	Clean			<input type="radio"/> (2)			
● Spark plug	Check-adjust				<input type="radio"/>		3-4
	Replace					<input type="radio"/>	
Spark arrester	Clean				<input type="radio"/>		3-8
● Combustion chamber	Clean	After every 300 Hrs.					10-13
● Valve clearance	Check-readjust					<input type="radio"/>	3-5
● Fuel tank and filter	Clean				<input type="radio"/>		3-7
● Fuel line	Check	Every 2 years (Replace if necessary)					3-7

● Emission related items.

(1): For commercial use, log hours of operation to determine proper maintenance intervals.

(2): Service more frequently when used in dusty areas.

**SERVICE BULLETIN #33 =>**

## 2. OIL ALERT

• For convenience, perform this test in conjunction with the engine oil change.

- 1) Drain the engine oil and perform the spark test (P. 2-12).

The oil alert light should go ON, and there should be no sparks at the spark plug electrodes.

- 2) Add engine oil to the specified level, and perform the spark test (P. 2-12).

The oil alert light should stay OFF, and the sparks jump across the spark plug electrodes.

- 3) If there is any abnormality, perform ignition system troubleshooting (P. 2-12 and 13).

## 3. ENGINE OIL

### Oil Level Check

Check the engine oil level with the engine stopped and the engine on a level surface.

- 1) Loosen the screw and remove the maintenance cover.
- 2) Remove the oil filler cap/dipstick, and check the oil level. It should be at the lower edge of the oil filler port.
- 3) If the oil level is low, add to the lower edge of the oil filler port.

Change the oil if it is dirty or contaminated with foreign material.

Recommended oil	SAE 10W-30 or SAE30 API Service category SJ
-----------------	--

Oil is a major factor affecting performance and service life. Use 4-stroke automotive detergent oil.

SAE 10W-30 is recommended for general use. Other viscosities shown in the chart may be used when the average temperature in your area is within the recommended range.

- 4) Install the oil filler cap/dipstick securely.

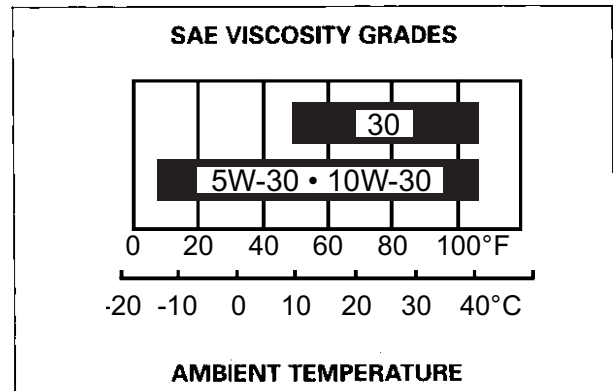
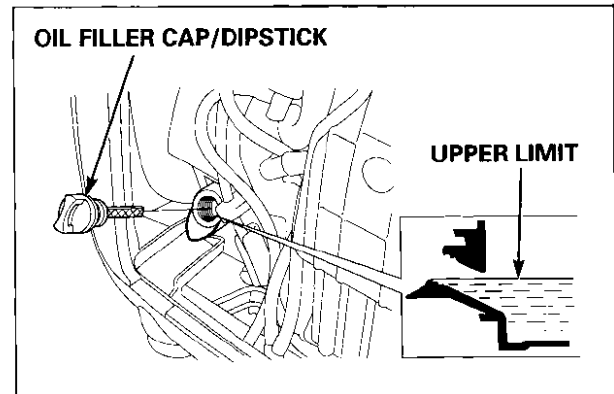
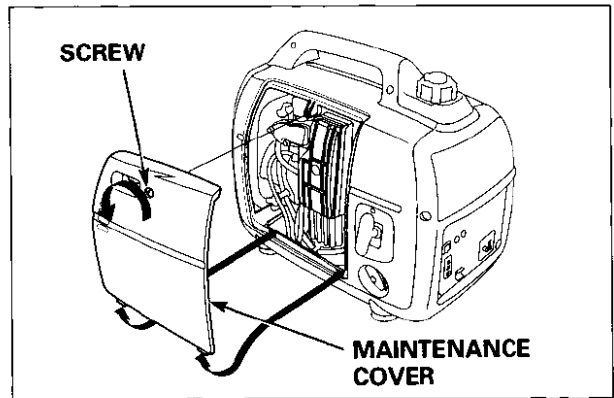

## EU2000i

### • Oil Change:

Drain the used oil while the engine is warm. Warm oil drains quickly and completely.

- 1) Remove the maintenance cover. Remove the oil filler cap and drain the engine oil into a suitable container.

Please dispose of the used motor oil in a manner that is compatible with the environment. We suggest that you take used oil in a sealed container to your local recycling center or service station for reclamation. Do not throw it in the trash, pour it on the ground, or down a drain.

### ⚠ CAUTION

Used engine oil contains substances that have been identified as carcinogenic.

If repeatedly left in contact with the skin for prolonged periods, it may cause skin cancer.

Wash your hands thoroughly with soap and water as soon as possible after contact with used engine oil.

- 2) Pour the specified amount of fresh engine oil through the oil filter port.

Engine oil capacity	0.40 ℓ (0.42 US qt, 0.35 Imp qt)
---------------------	-------------------------------------

- 3) After refilling, check the oil level again. If the level is low, add to the lower edge of the filler neck.

Do not overfill. If the engine is overfilled, the excess oil may get transferred to the air cleaner housing and the air filters.

## 4. AIR CLEANER

A dirty air cleaner will restrict air flow to the carburetor, reducing engine performance. If the engine is operated in dusty areas, clean the air cleaner more often than specified in the *MAINTENANCE SCHEDULE*.

### NOTICE

*Operating the engine without air filters or with damaged air filters, will allow dirt to enter the engine, causing rapid engine wear.*

### Inspection/Cleaning

- 1) Loosen the cover screw and remove the maintenance cover.
- 2) Loosen the cover screw and remove the air cleaner cover.
- 3) Remove the filters from the air cleaner case.

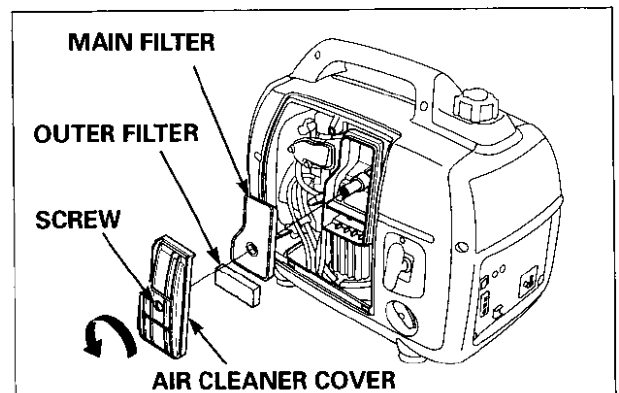
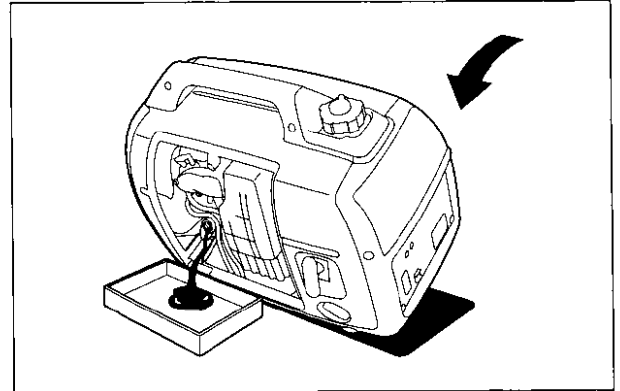

- 4) Clean the filters in warm soapy water, rinse and allow to dry thoroughly, or clean with a high flash point solvent and allow to dry.

Dip the filters in clean engine oil and squeeze out all the excess oil.

- Excess oil will restrict air flow through the foam filter and may cause the engine to smoke at startup.
- 5) Install the air cleaner filters in the air cleaner case.
- Clean the air cleaner rubber and the air cleaner case if necessary.
  - Be sure that the air cleaner cover seal is set securely.
- 6) Install the air cleaner cover.
- Set the air cleaner cover on the air cleaner case and tighten the cover screw securely.
  - Be sure that the air cleaner cover seal is set securely. Replace the cover seal if damaged.

#### NOTICE

*A loose air cleaner cover can vibrate off while the generator is running. Operating the engine without air cleaner filters or with damaged air cleaner filters will allow dirt to enter the engine, causing rapid engine wear.*

- 7) Install the maintenance cover securely.

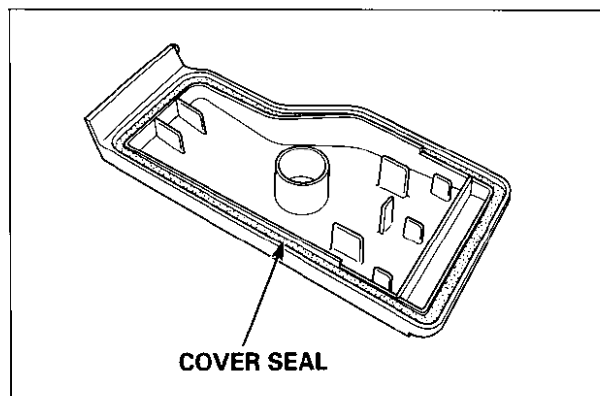
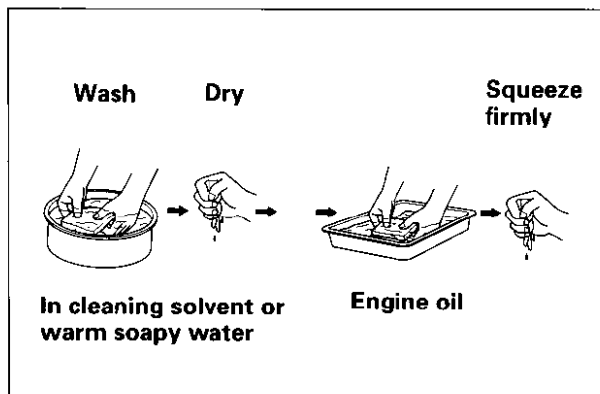

## 5. SPARK PLUG

### Inspection/Cleaning:

If the engine has been running, the engine will be very hot. Allow it to cool before proceeding.

- 1) Remove the plug cover.
- 2) Remove the spark plug cap, and remove the spark plug using a spark plug wrench.

Visually inspect the spark plug. Discard the plug if the insulator is cracked or chipped.

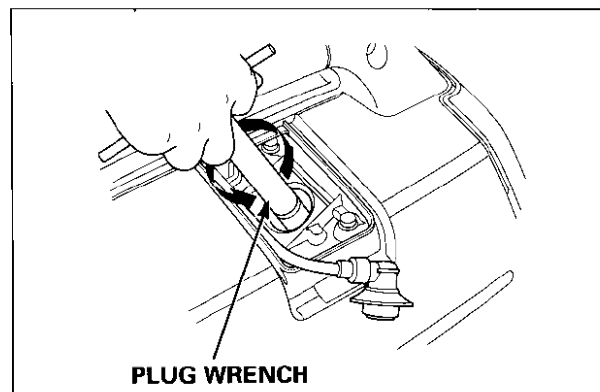

## EU2000i

- 4) Remove carbon or other deposits with a plug cleaner or stiff wire brush. Check the sealing washer for damage.
- 5) Measure the plug gap with a wire-type feeler gauge. If the measurement is outside the specification, adjust by bending the side electrode.

Spark plug gap	0.6 – 0.7 mm
----------------	--------------

Recommended spark plug	NGK	CR5HSB
------------------------	-----	--------

- 5) Install the plug fingertight to seat the washer, then tighten with a plug wrench.
  - If reinstalling the used spark plug, tighten 1/8 – 1/4 turn after the spark plug seats.
  - If installing a new spark plug, tighten 1/2 turn after the spark plug seats.

### NOTICE

*A loose spark plug can become very hot and can damage the engine. Overtightening can damage the threads in the cylinder block.*

- 6) Install the spark plug cap and plug cover.

## 6. VALVE CLEARANCE

- Valve clearance inspection and adjustment must be performed with the engine cold.

### Inspection:

- 1) Remove the following parts.
  - Rear cover (P. 4-1).
  - Front cover, control panel (P. 6-1)
  - Right and left side covers (P. 7-1)
  - Fuel tank (P. 7-2)
  - Front frames under cover (P. 7-3)
  - Recoil starter, fan cover (P. 8-1)
  - Right and left shrouds (P. 8-5)
- 2) Loosen the four 6 x 28 mm flange bolts.
- 3) To remove the head cover, insert a screwdriver or equivalent tool into the cylinder recess as shown. Remove the head cover slowly.

- Clean up any spilled engine oil with a shop towel when removing the head cover.

### NOTICE

- Do not remove the head cover with force, because that can deform the head cover.
- Replace the head cover if it is deformed.

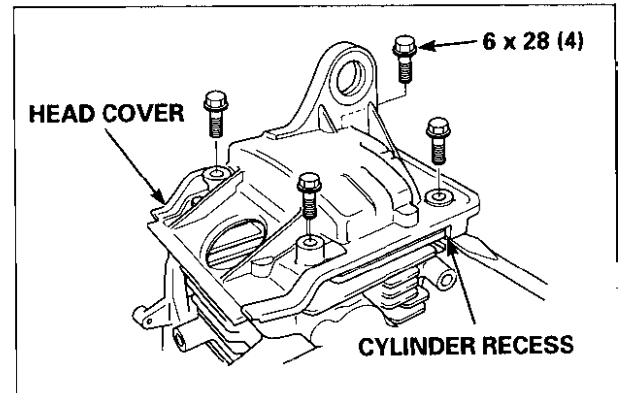
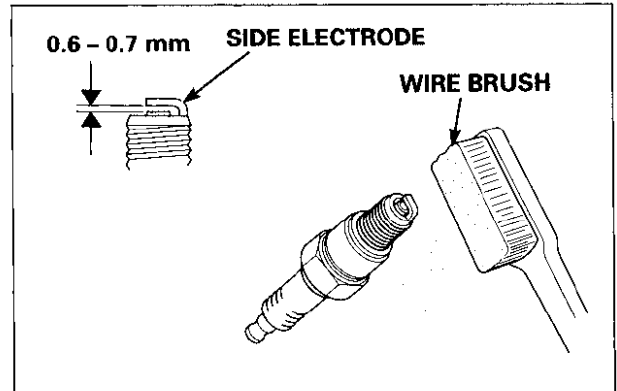

- 4) Remove the recoil starter (P. 8-1)
- 5) Set the piston top dead center of the compression stroke (both valves fully closed). Align the alignment point of the starter pulley with the "▲" mark on the fan cover.

- If the exhaust valve opens when the alignment mark of the starter pulley with the "▲" mark on the fan cover, turn the flywheel one turn and align the marks.

The top dead center of the compression stroke is in the position where the head cover mating surface is in line with the cam pulley alignment marks.

- 6) Insert a feeler gauge between the valve adjusting screw and the valve and measure the valve clearance.

Valve clearance	IN	$0.15 \pm 0.02$ mm
	EX	$0.20 \pm 0.02$ mm

### Adjustment:

- 1) If adjustment is necessary, proceed as follows.
  - a. Hold the valve adjusting screw using the special tool, and loosen the lock nut.

#### TOOL:

Valve adjuster wrench, 3 mm                      07908-KE90200

- b. Turn the adjusting screw to obtain the specified intake and exhaust valve clearance.
  - c. Hold the valve adjusting screw using the special tool, and tighten the lock nut.

**TORQUE: 7.5 N·m (0.75 kgf·m, 5.4 lbf·ft)**

- 2) Recheck valve clearance after tightening the lock nut.
- 3) Clean the head cover installation surface of the cylinder block and head cover. Apply the liquid gasket (Three Bond 1207E, Hondabond #4, or equivalent) to the cylinder block installation surface as shown, and install the head cover.

Assemble the head cover within 3 minutes after application of the liquid gasket.

- 4) Tighten the 6 x 28 mm flange bolts.
- 5) Install the removed parts in the reverse order of removal.

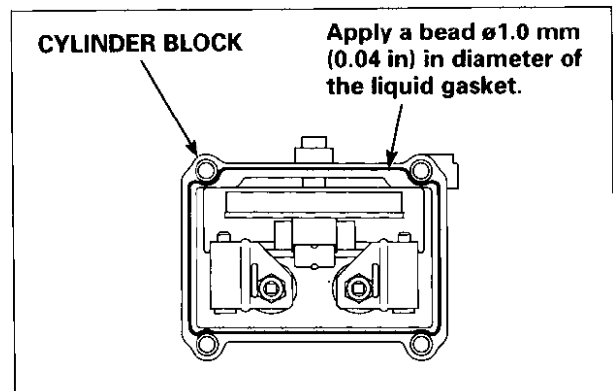
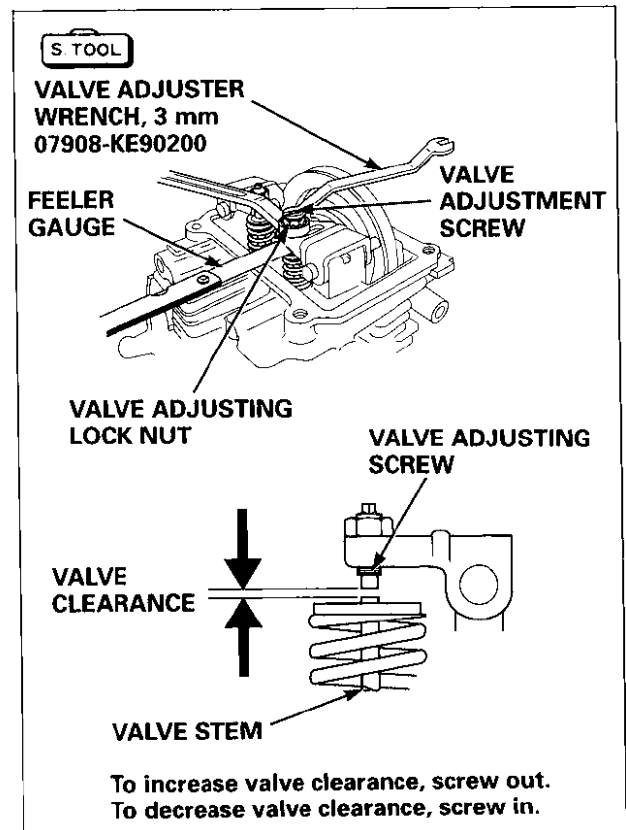
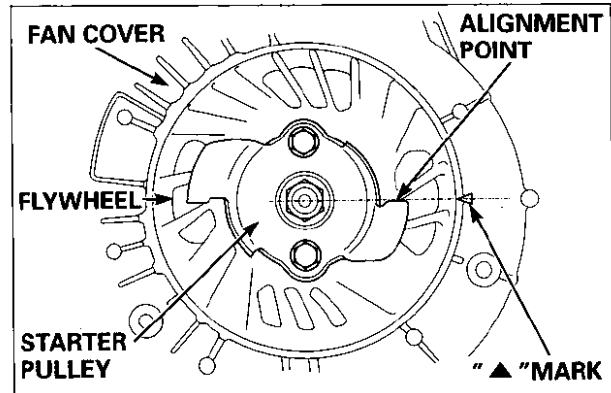

**EU2000i****7. FUEL TANK/FUEL FILTER****⚠ WARNING**

Gasoline is highly flammable and explosive.

You can be burned or seriously injured when handling fuel.

- Keep heat, sparks, and flame away.
- Handle fuel only outdoors.
- Wipe up spills immediately.

**Cleaning:**

- 1) Drain the fuel from the tank and carburetor, then remove the following parts.
  - Rear cover (P. 4-1)
  - Front cover and control panel (P. 6-1)
  - Right and left side covers (P. 7-1)
- 2) Disconnect the fuel tube from the fuel tank, and remove the fuel filter.
- 3) Remove any foreign material from the fuel filter, and check the fuel filter for damage. Replace the fuel filter if necessary.
- 4) Remove the fuel tank, clean it with cleaning solvent, and allow the fuel tank to dry thoroughly.
- 5) After cleaning, install the fuel tank and set the fuel strainer in the tank. Connect the fuel tube.
- 6) Install the removed parts in the reverse order of removal.
- 7) Fill the fuel tank with gasoline, and check the fuel tube for gasoline leakage.

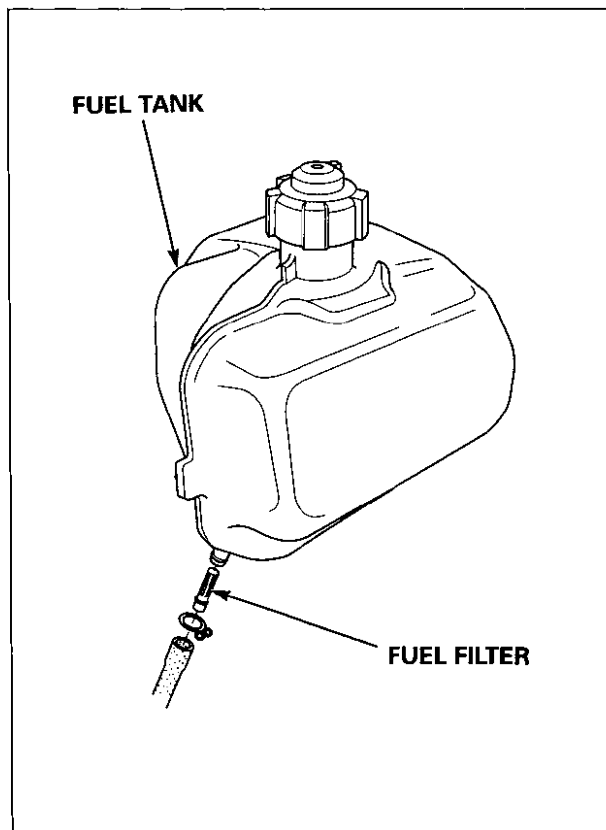
**8. FUEL TUBE/FUEL PUMP/  
DIAPHRAGM TUBE****⚠ WARNING**

Gasoline is highly flammable and explosive.

You can be burned or seriously injured when handling fuel.

- Keep heat, sparks, and flame away.
- Handle fuel only outdoors.
- Wipe up spills immediately.

**Inspection/Replacement:**

- 1) Drain the fuel from the tank and carburetor, then remove the following parts.
  - Rear cover (P. 4-1)
  - Front cover and control panel (P. 6-1)
  - Right and left side covers (P. 7-1)
  - Left front frame (P. 7-3)



- 2) Check the fuel tube for deterioration, cracks and gasoline leakage.
  - If there is any abnormality in the fuel tube, replace the tube.
- 3) Check the diaphragm tube for deterioration, cracks and oil leakage.
  - If there is any abnormality in the diaphragm tube, replace the tube.
- 4) Check to see if water or foreign material are in the fuel pump.
  - If there is water or foreign material in the fuel pump, replace the pump.
- 5) After assembly, check for gasoline leakage from each part.

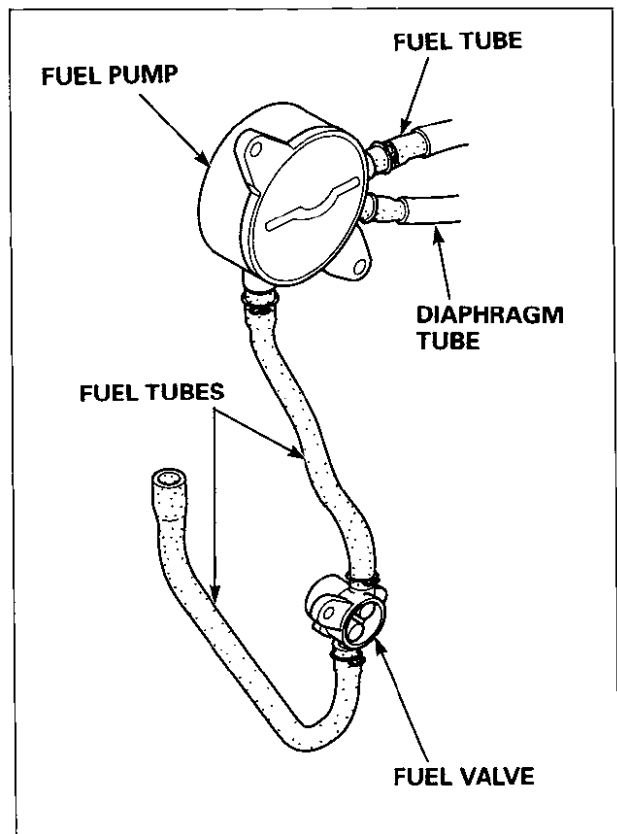

## 9. SPARK ARRESTER

### Cleaning

#### ⚠ CAUTION

The engine and muffler become very hot during operation and they remain hot for a while after operation. Be sure that the engine is cool before muffler removal/installation.

- 1) Remove the four 6 mm special screws and rear cover.
- 2) Remove the three 6 mm flange bolts and muffler.
- 3) Remove the spark arrester from the muffler. Check for carbon deposits around the exhaust port and the spark arrester, and clean if necessary.
- 4) Use a brush to remove carbon deposits from the spark arrester screen.

#### NOTICE

*Be careful to avoid damaging the screen.*

The spark arrester must be free of breaks and holes. Replace the spark arrester if it is damaged.

- 5) Reinstall the removed parts in the reverse order of removal.

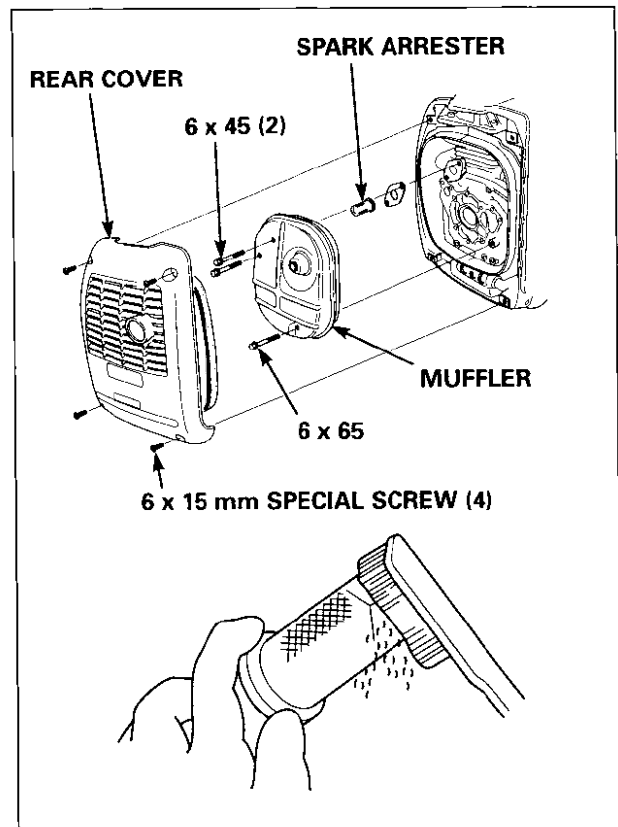

# 4. MUFFLER

## EU2000i

1. MUFFLER.....	4-1
-----------------	-----

### 1. MUFFLER

#### a. DISASSEMBLY/REASSEMBLY

- Muffler removal/installation must be performed with the engine cold.

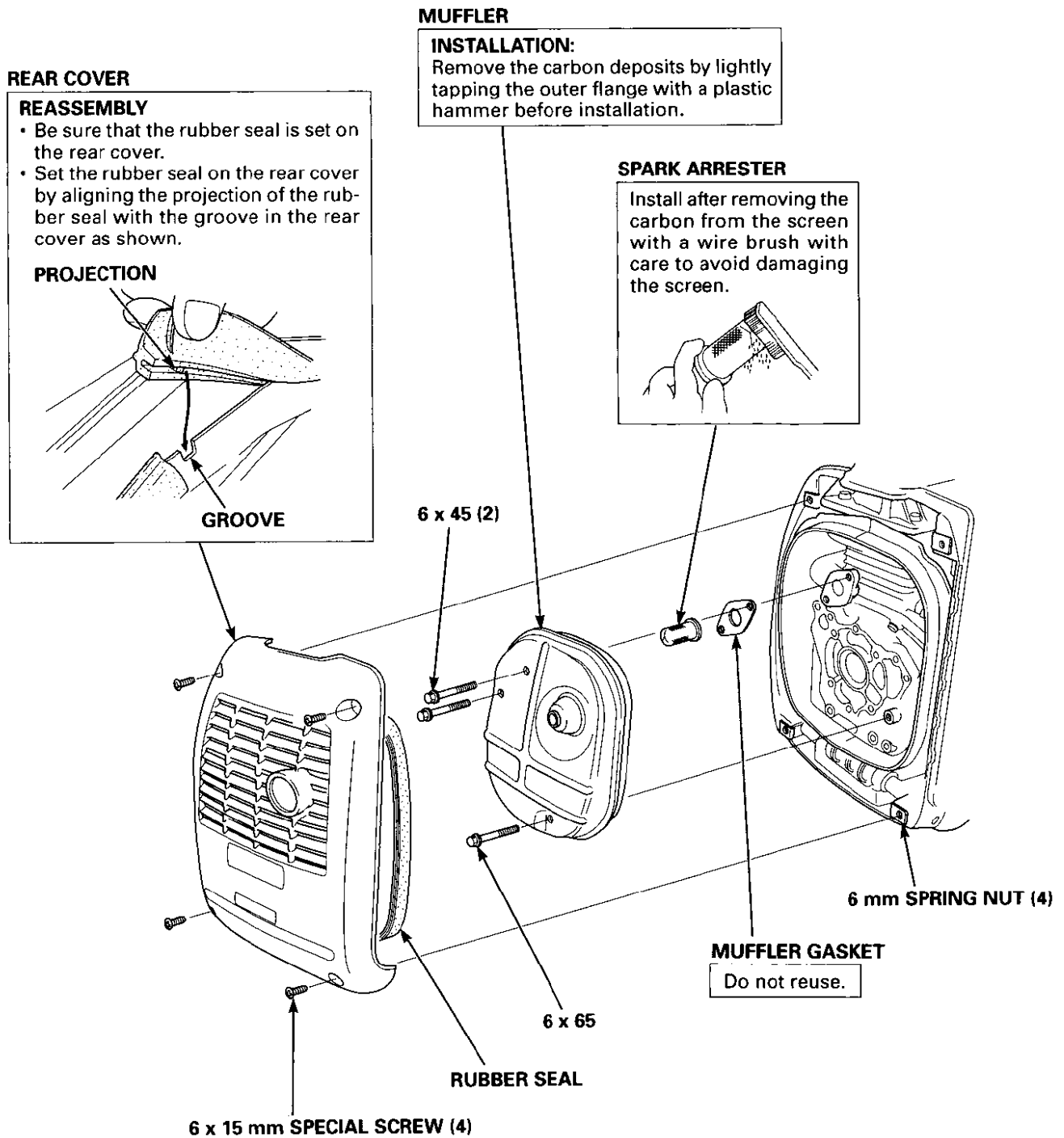



# 5. AIR CLEANER/CARBURETOR

1. AIR CLEANER .....	5-1	2. CARBURETOR.....	5-2
----------------------	-----	--------------------	-----

## 1. AIR CLEANER

### a. DISASSEMBLY/REASSEMBLY

#### **⚠ WARNING**

Gasoline is highly flammable and explosive.

You can be burned or seriously injured when handling fuel.

- Keep heat, sparks, and flame away.
- Handle fuel only outdoors.
- Wipe up spills immediately.

Loosen the drain screw to drain the carburetor thoroughly before removal.

#### **NOTICE**

*If the air cleaner removal/installation is made with the carburetor installed, hand tighten the two 5 mm flange nuts. Turn the choke lever fully closed position to prevent dust and dirt from entering the engine.*

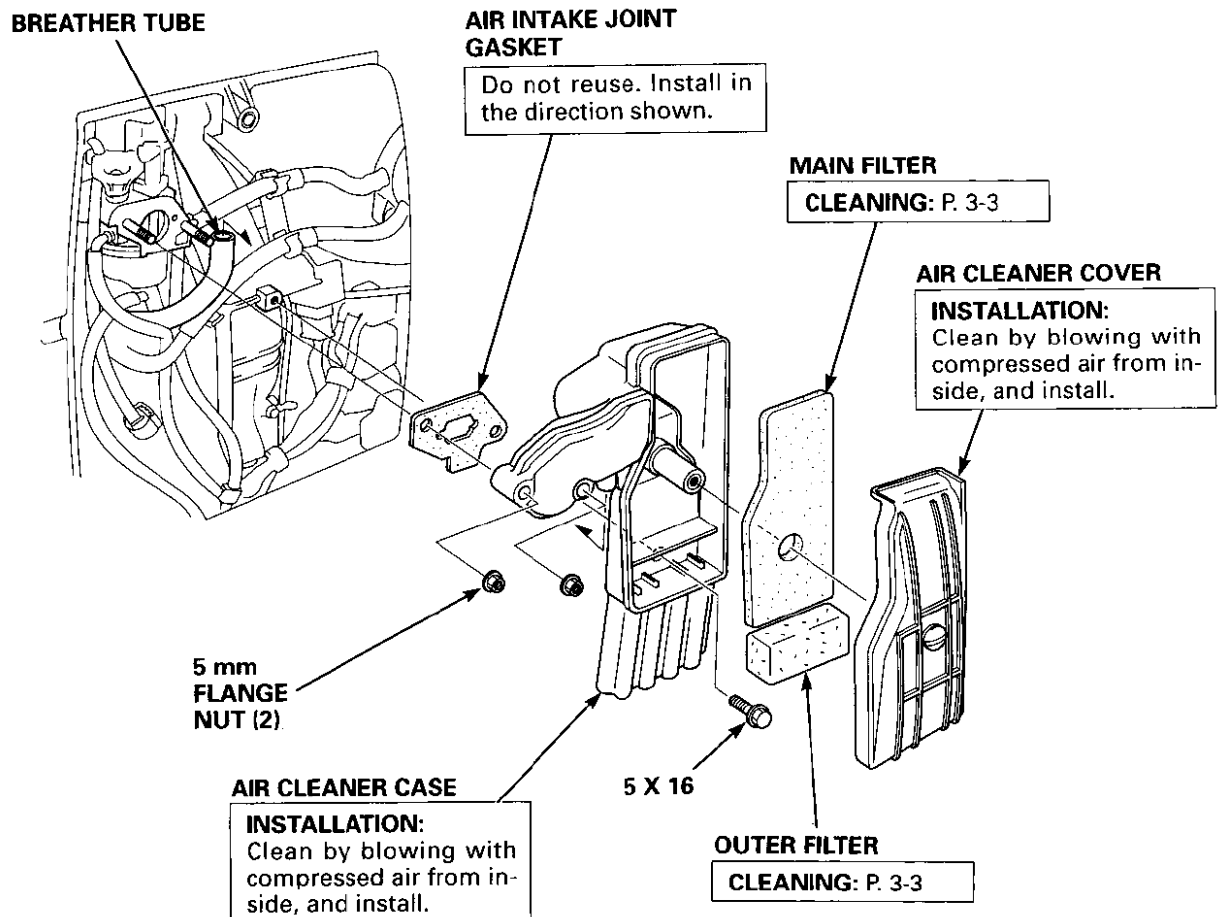

## 2. CARBURETOR

### a. REMOVAL/INSTALLATION

#### ⚠ WARNING

Gasoline is highly flammable and explosive.

You can be burned or seriously injured when handling fuel.

- Keep heat, sparks, and flame away.
- Handle fuel only outdoors.
- Wipe up spills immediately.

Loosen the drain screw to drain the carburetor thoroughly before removal.

#### NOTICE

- Cover the intake port with clean tape or film to prevent dirt from entering into the engine.
- If these parts are left out, dirt will enter the intake system.

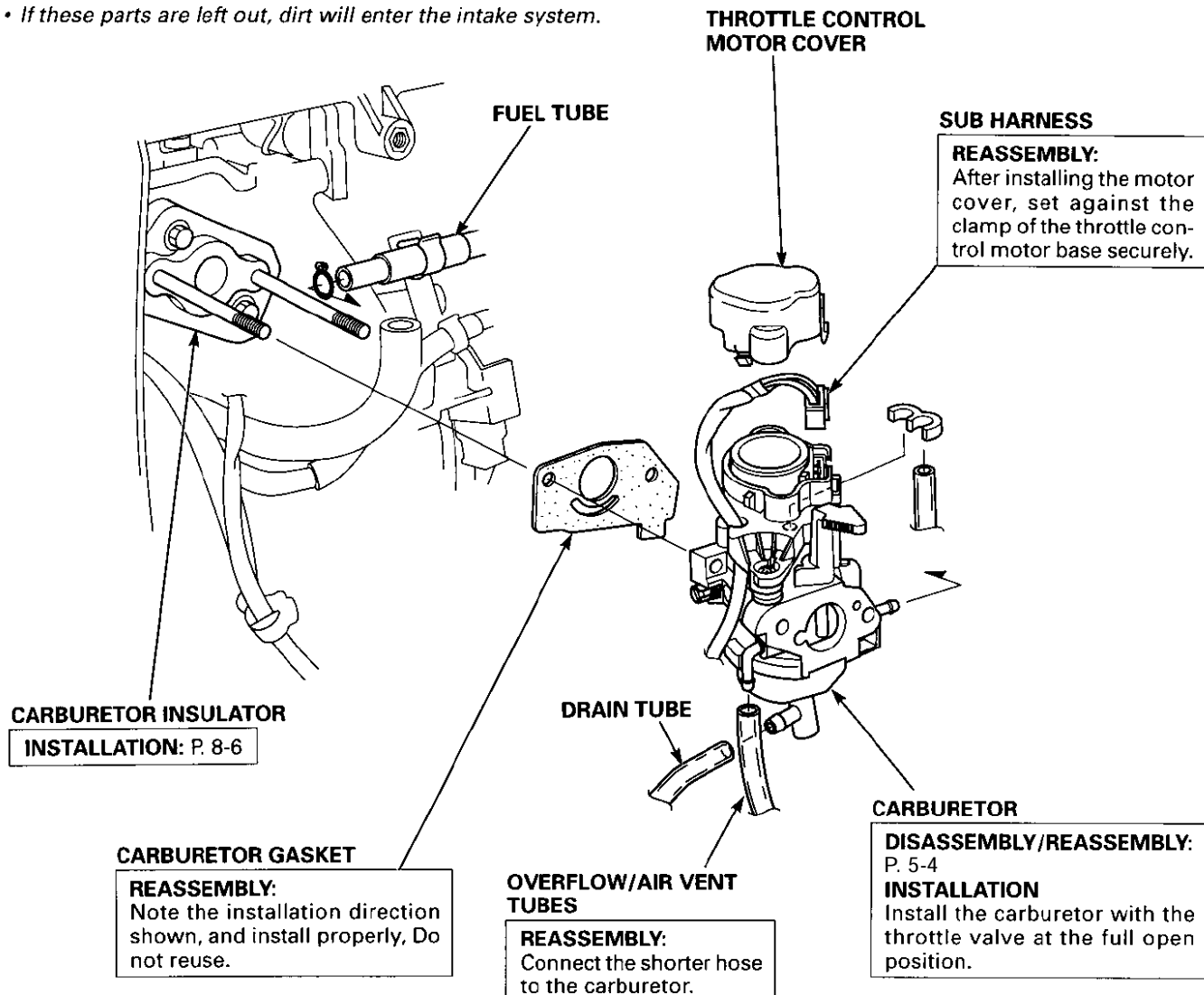

# EU2000i

## b. DISASSEMBLY/REASSEMBLY

### • THROTTLE CONTROL MOTOR

#### **⚠ WARNING**

Gasoline is highly flammable and explosive.

You can be burned or seriously injured when handling fuel.

- Keep heat, sparks, and flame away.
- Handle fuel only outdoors.
- Wipe up spills immediately.

Loosen the drain screw to drain the carburetor thoroughly before disassembly.

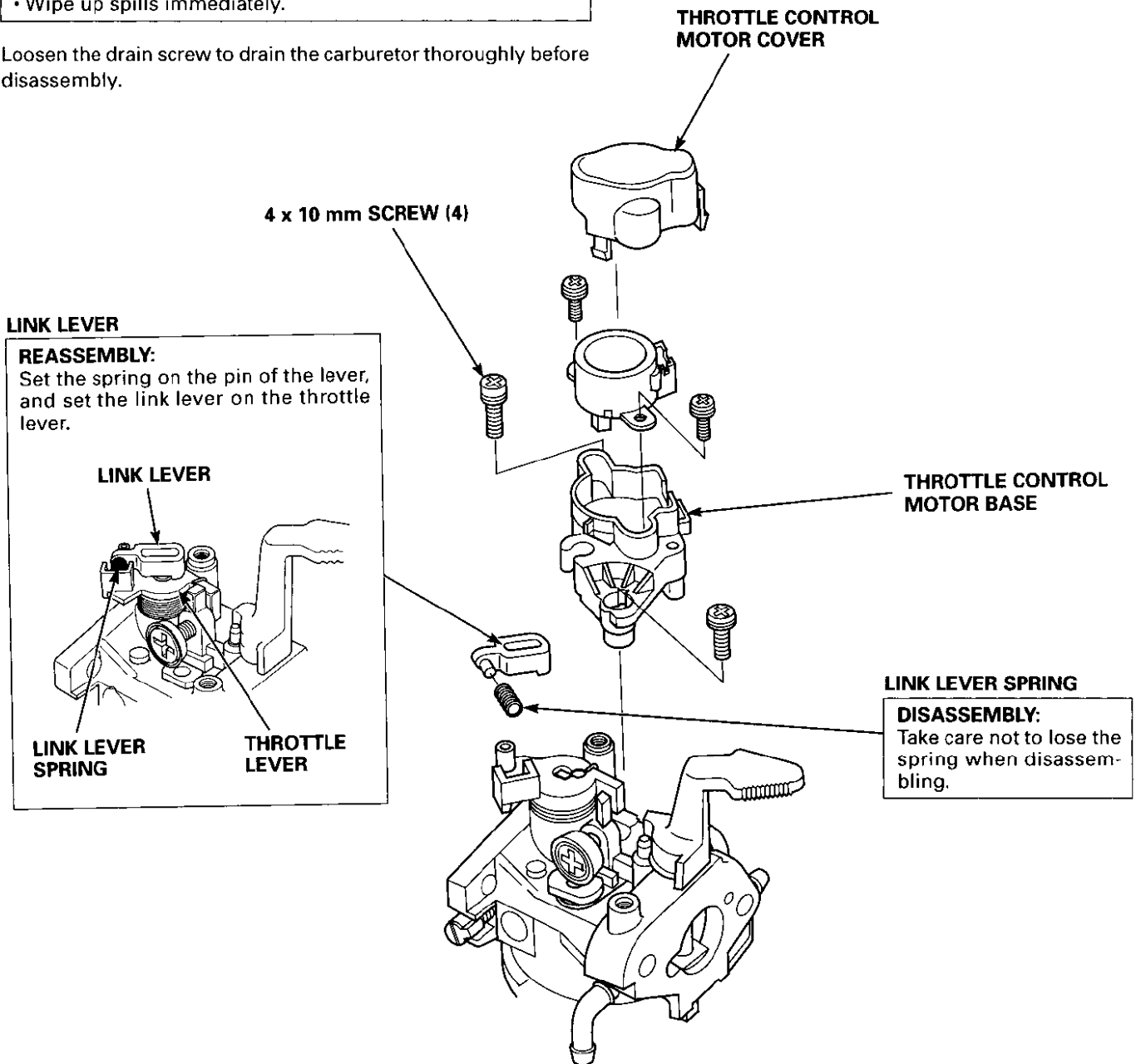

● CARBURETOR

GENERAL INFO #19 =>

**⚠ WARNING**

Gasoline is highly flammable and explosive.  
 You can be burned or seriously injured when handling fuel.

- Keep heat, sparks, and flame away.
- Handle fuel only outdoors.
- Wipe up spills immediately.

Loosen the drain screw to drain the carburetor thoroughly before disassembly.

**PILOT JET**

**REASSEMBLY:**

- Clean the passage by blowing compressed air before installation.
- Apply light coat of oil to the O-ring to facilitate installation.

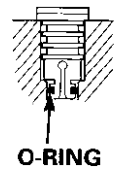

**CARBURETOR BODY**

**REASSEMBLY:**

Clean the body by blowing compressed air before installation.

**THROTTLE STOP SCREW**

**INSTALLATION:** P.5-5

**PILOT SCREW**

The pilot screw is fitted with a limiter cap. Do not attempt to remove the limiter cap for pilot screw adjustment. The limiter cap cannot be removed without breaking the pilot screw.

**REPLACEMENT:** P.5-5

**LIMITER CAP**

**REPLACEMENT:** P.5-5

**MAIN NOZZLE**

**REASSEMBLY:**

Clean the passage by blowing compressed air before installation.

**MAIN NOZZLE**



**FLOAT VALVE**

**REASSEMBLY:**

Check the float valve tip for wear and check the spring for operation.

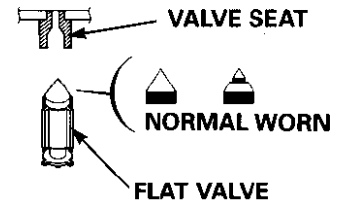

**MAIN JET**

**REASSEMBLY:**

Clean the passage by blowing compressed air before installation.  
**Main jet: #62**

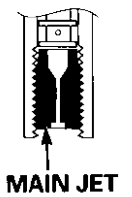

**FLOAT PIN**

**FLOAT CHAMBER**

**REASSEMBLY:**

Install with the drain screw facing the air cleaner side.

**ENGINE SIDE**

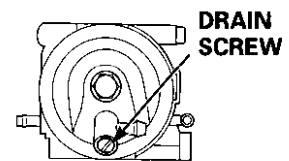

**AIR INTAKE JOINT SIDE**

**FLOAT**

**REASSEMBLY:**

After installation, check for operation by lightly pushing with a finger.  
**INSPECTION:** P. 5-6

**FLOAT CHAMBER GASKET**

**SEALING WASHER**

**SET BOLT**

**REASSEMBLY:**

Tighten the bolt securely and check for gasoline leakage.

**O-RING**

**DRAIN SCREW**

1.5 N·m (0.15 kgf·m, 1.1 lbf·ft)

## EU2000i

### ● PILOT SCREW AND LIMITER CAP REPLACEMENT

Leave the pilot screw and limiter cap in place during carburetor cleaning. Remove only if necessary for carburetor repair.

Removal of the limiter cap requires breaking the pilot screw. A new pilot screw and limiter cap must be installed.

- 1) When the limiter cap has been broken off, remove the broken pilot screw.
- 2) Place the spring on the replacement pilot screw, and install it on the carburetor.
- 3) Turn the pilot screw in until it is lightly seated; then turn the screw out the required number of turns.

Pilot screw opening	2 – 5/8 turns out
---------------------	-------------------

- 4) Apply Loctite® 638 to the inside of the new limiter cap, then install the cap so its stop prevents the pilot screw from being turned counterclockwise.

Be careful to avoid turning the pilot screw while installing the limiter cap. The pilot screw must stay at its required setting.

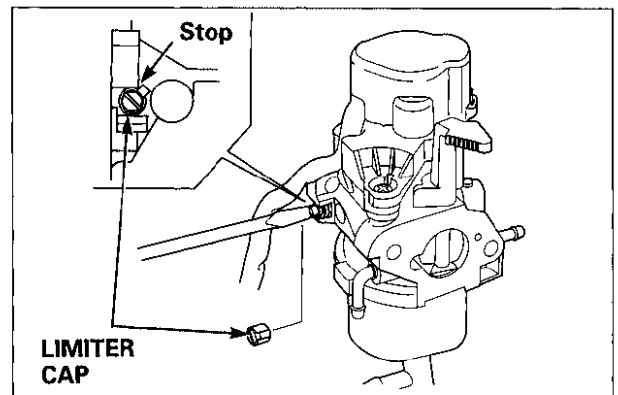
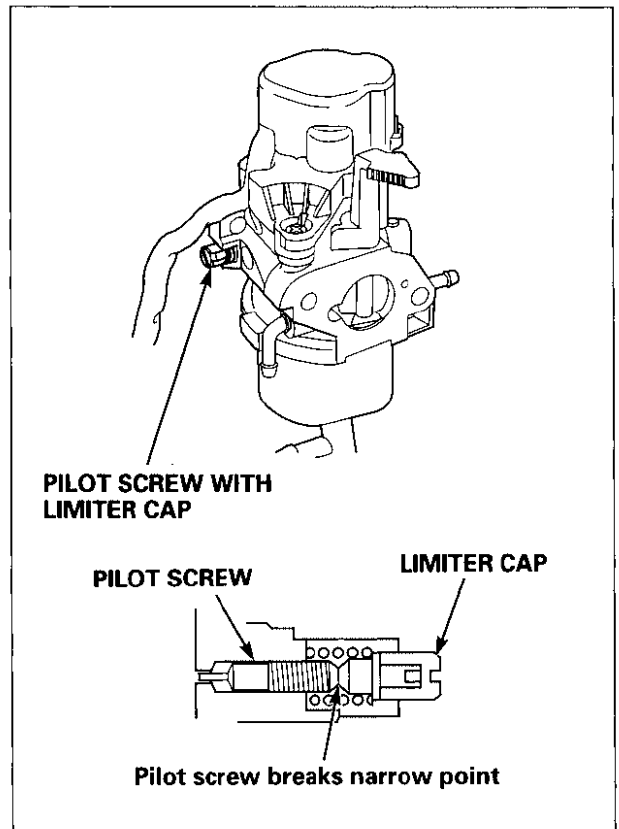

### ● THROTTLE STOP SCREW

Install the throttle stop screw after installing the pilot jet.

- 1) Install so that the throttle valve is at the full close position and the screw end does not come out of the bracket.
- 2) Start the engine, turn the ECO throttle switch on. Wait until the engine warms up.
- 3) Turn the throttle stop screw in until the engine speed starts to increase: then turn the screw out 3/5 turns.

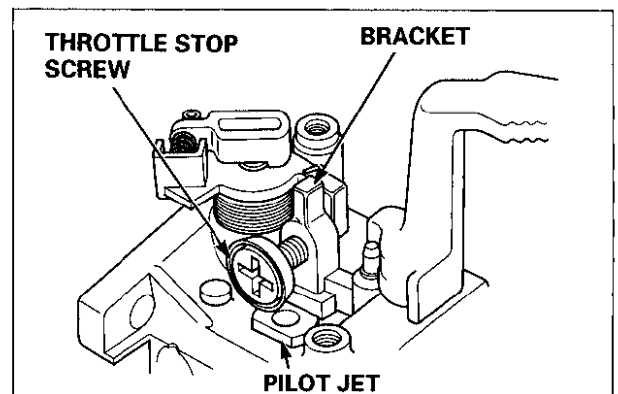



### c. INSPECTION

#### ● FLOAT LEVEL HEIGHT

With the carburetor in an upright position, measure the distance between the float top and carburetor body when the float just contacts the float valve.

Standard float height	12.0 mm (0.47 in)
-----------------------	-------------------

If the height is outside the specification, replace the float.  
Check the float operation.

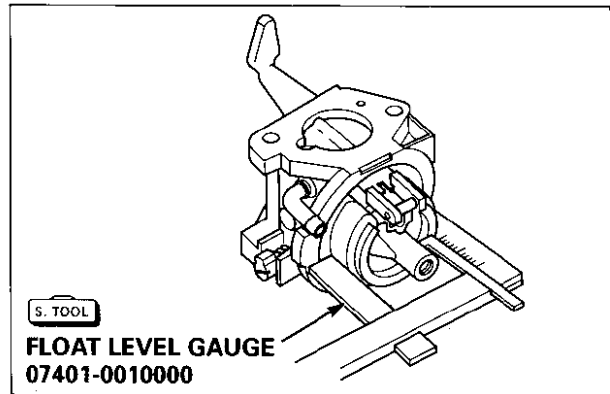

#### ● THROTTLE CONTROL MOTOR

Measure the resistance between the terminals.

Standard resistance	Between 1 and 3: 50 – 70 $\Omega$ Between 2 and 4: 50 – 70 $\Omega$
---------------------	--

If the resistance is outside the specification, replace the throttle control motor.

#### Operation check:

Start the engine and stop it. Be sure that the throttle control motor functions and the carburetor throttle arm moves properly.

- At start: Returns from the full open position to the full close position.
- At stop: Returns to the full open position.

If the throttle control motor does not operate properly, replace.

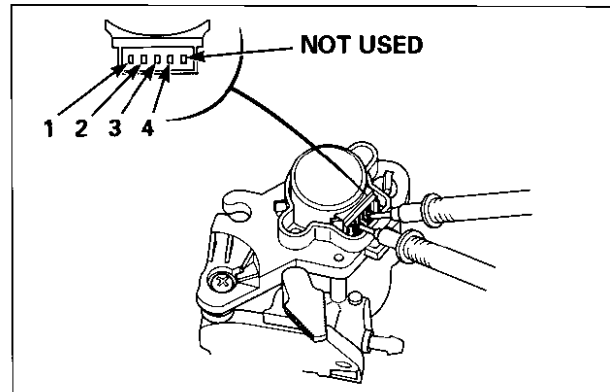

# 6. CONTROL PANEL

**EU2000i**

1. CONTROL PANEL ..... 6-1
----------------------------

## 1. CONTROL PANEL

### a. REMOVAL/INSTALLATION

- 1) Disconnect the connectors from the inverter unit and the generator wire harness.
- 2) Remove the control panel from upper side.
- 3) Remove the two composite socket terminals and the AC receptacle terminals.

**SERVICE BULLETIN #34 =>**

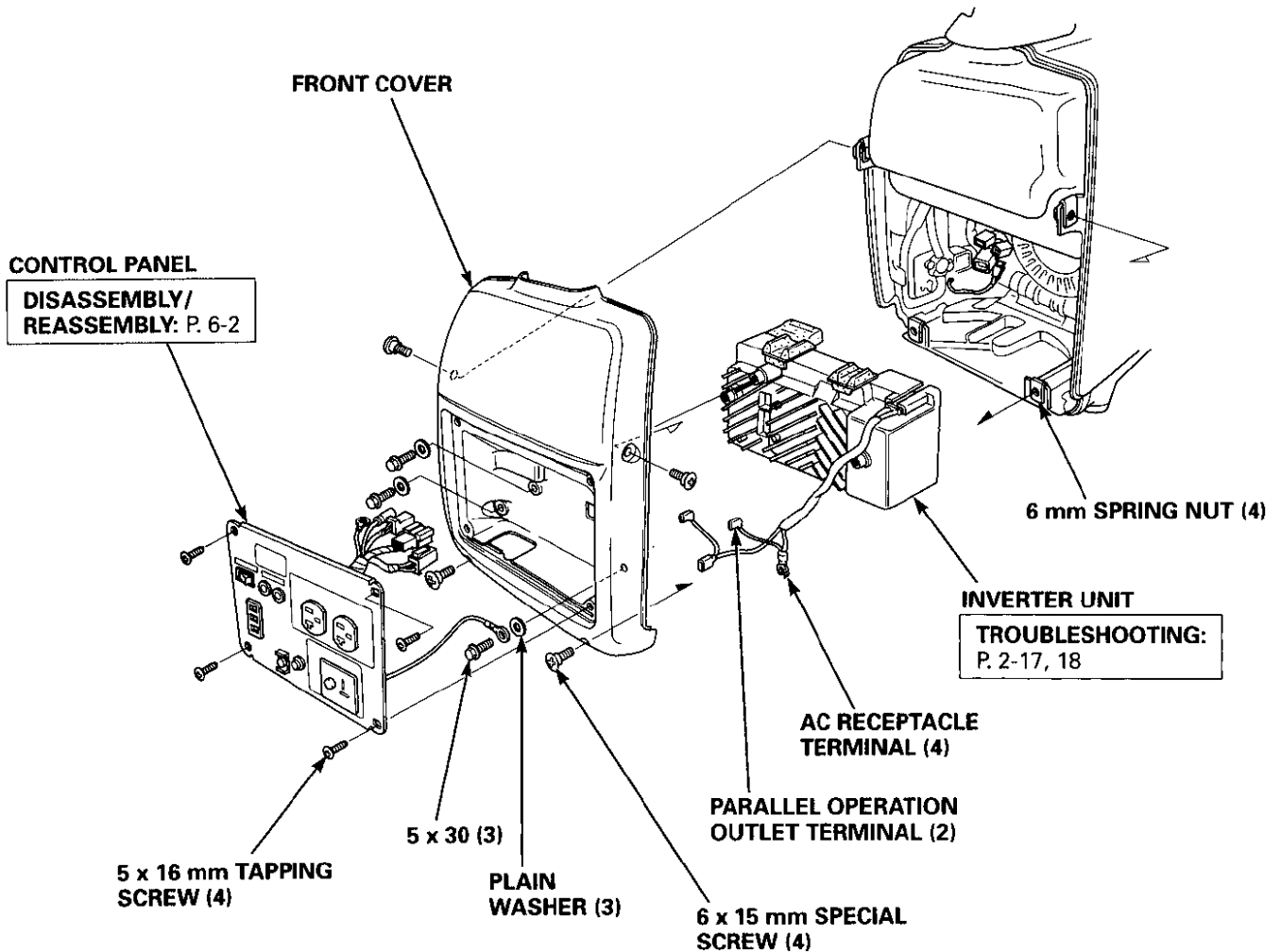

b. DISASSEMBLY/REASSEMBLY

**SERVICE BULLETIN #34 =>**

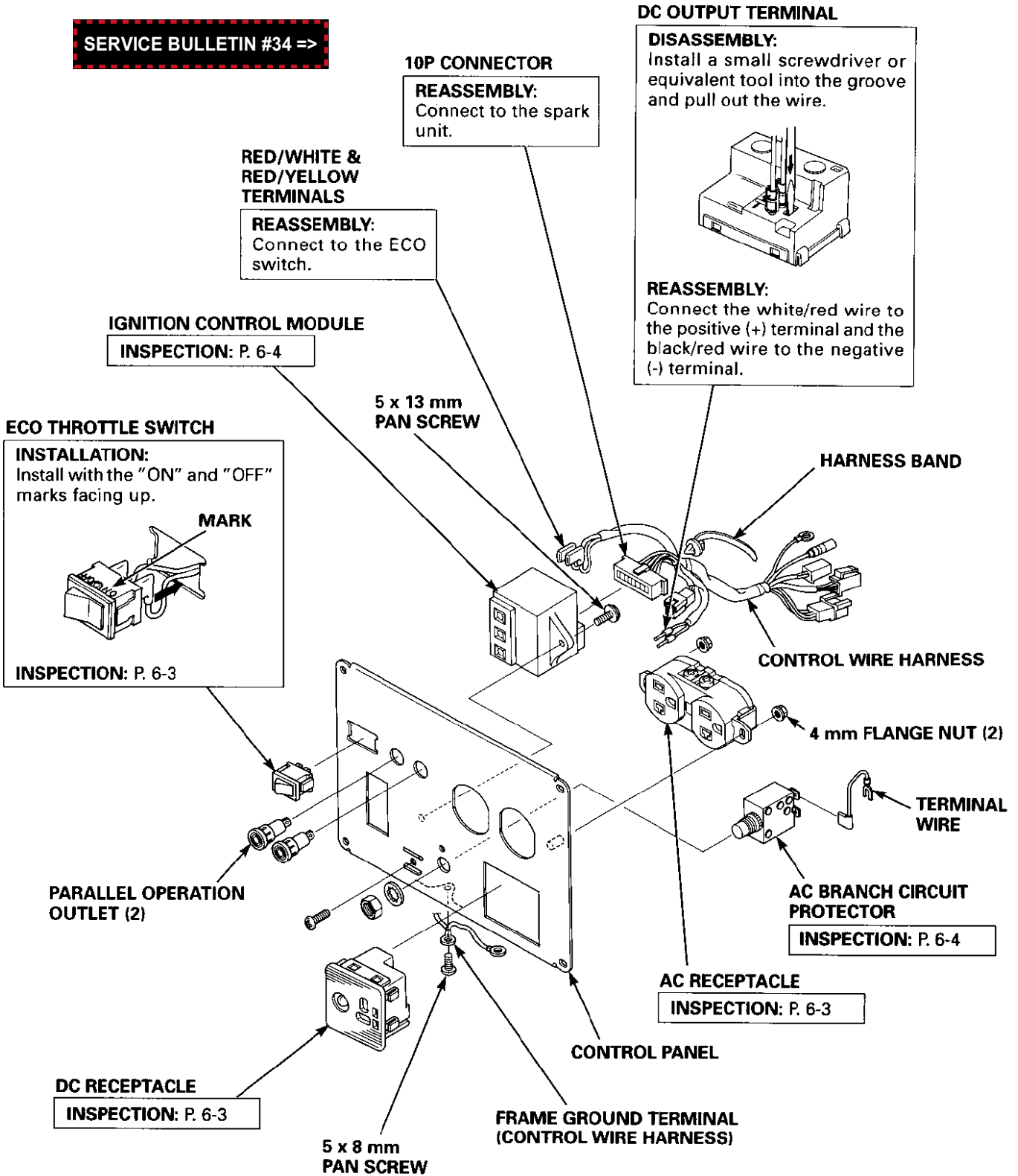

## EU2000i

### c. INSPECTION

#### • AC RECEPTACLE

- Connect both terminals of the receptacle with a jumper wire to short. There must be continuity between the lead wire terminals.
- There must be continuity between the ground terminal of the receptacle and the receptacle installation fitting.

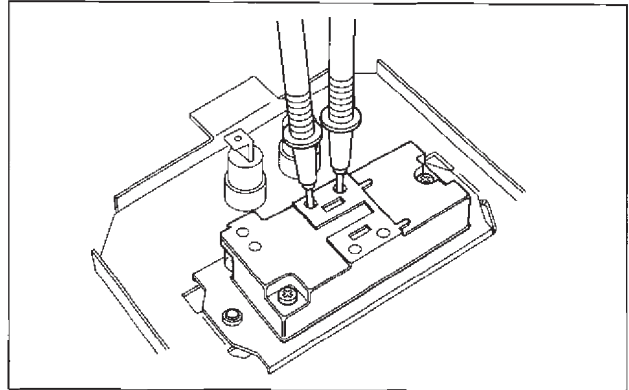

#### • DC RECEPTACLE

Connect both terminals of the receptacle with a jumper wire to short. There must be continuity between the lead wire terminals with the circuit protector ON.

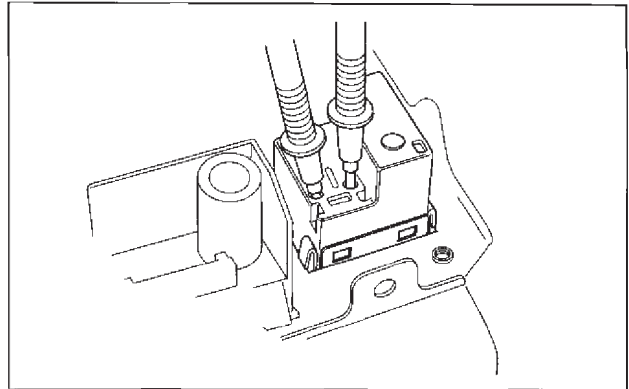

#### • COMPOSITE SOCKET

There must be continuity between the socket and the terminal.

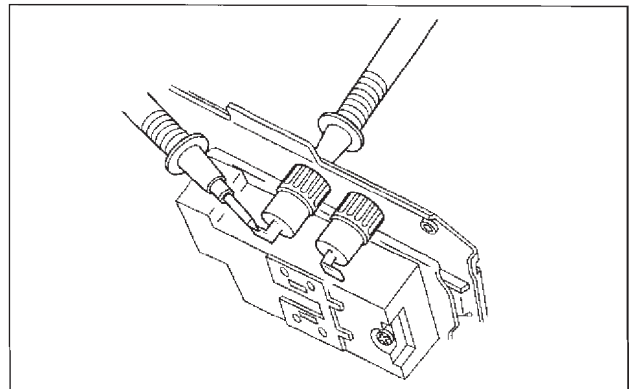

#### • ECO SWITCH

Check for continuity between the switch terminals.

There must be no continuity with the switch turned ON, and continuity with the switch turned OFF.

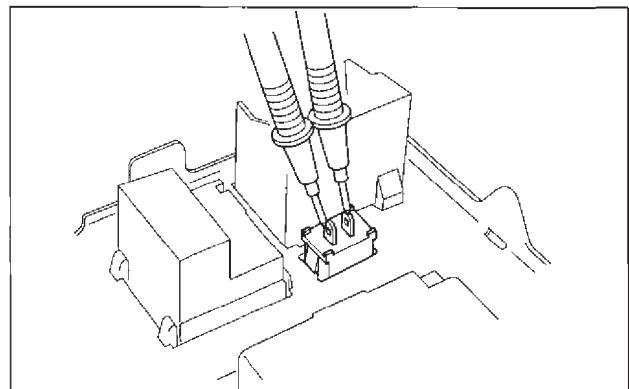

### ● AC CIRCUIT PROTECTOR

There must be continuity between the terminals with the switch ON.

There must be no continuity between the terminals with the switch OFF.

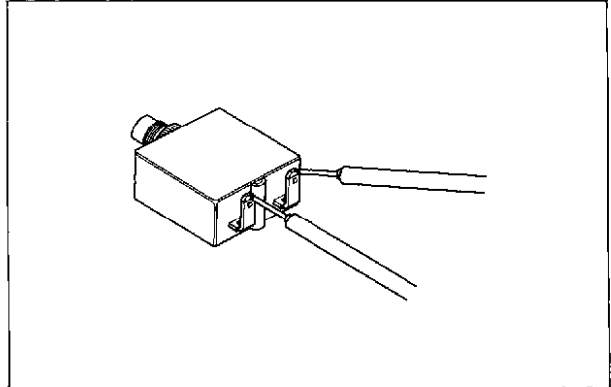

### ● IGNITION CONTROL MODULE

- 1) Remove the front cover.
- 2) Remove the four 5 x 16 mm screws, and pull off the control panel from the generator. Do not disconnect the control panel wire harness.
- 3) Disconnect the 10P ignition control module connector from the ignition control module.
- 4) Test the wire harness according to the table below. If it is normal, replace the ignition control module.

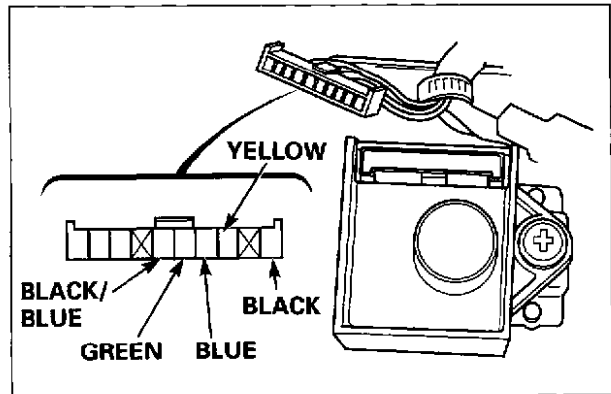

Color	Circuit	Test and result
Black	Primary coil	Check for resistance to engine ground. Resistance: 0.7 – 1.1 $\Omega$
Yellow	Oil level switch	Check for continuity to engine ground. There should be no continuity with correct oil level.
Blue	Igniton pulse generator	Check for resistance to engine ground. Resistance: 300 – 360 $\Omega$
Green	Ground	Check for continuity to engine ground. There should be continuity.
Black/blue	Exciter coil	Check for resistance to engine ground. Resistance: 0.2 – 0.3 $\Omega$

# 7. SIDE COVERS/FUEL TANK/ FRONT FRAMES/UNDER COVER

## EU2000i

1. SIDE COVERS .....	7-1	3. FRONT FRAMES/UNDER COVER .....	7-3
2. FUEL TANK.....	7-2		

### 1. SIDE COVERS

#### a. REMOVAL/INSTALLATION

**⚠ WARNING**

Gasoline is highly flammable and explosive.  
You can be burned or seriously injured when handling fuel.

- Keep heat, sparks, and flame away.
- Handle fuel only outdoors.
- Wipe up spills immediately.

• Side cover removal/installation can be made with the carburetor and muffler installed.

- 1) Remove the rear cover (P. 4-1)
- 2) Remove the front cover and control panel (P. 6-1)
- 3) Remove the maintenance cover and drain the engine oil into a suitable container.

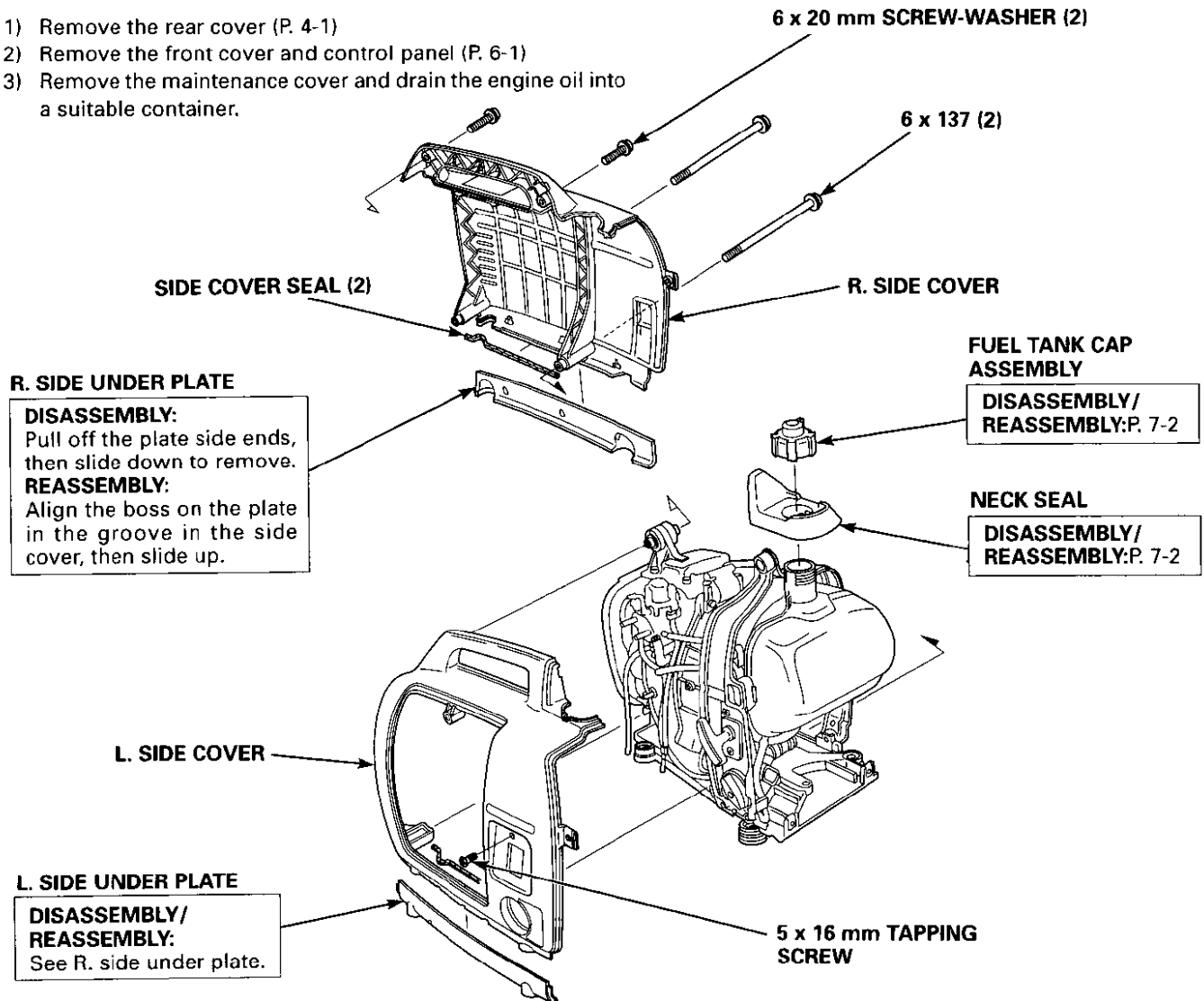

## 2. FUEL TANK

### a. DISASSEMBLY/REASSEMBLY

#### **⚠ WARNING**

Gasoline is highly flammable and explosive. You can be burned or seriously injured when handling fuel.

- Keep heat, sparks, and flame away.
- Handle fuel only outdoors.
- Wipe up spills immediately.

- 1) Remove the rear cover (P. 4-1)
- 2) Remove the front cover and control panel (P. 6-1)
- 3) Remove the right and left side covers (P. 7-1)

#### NECK SEAL

##### REASSEMBLY:

Align the groove in the seal with the boss on the tank.

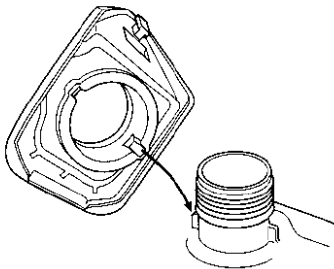

#### TANK STRAINER

##### INSTALLATION:

Remove any foreign material from the strainer. Check the tank strainer for damage before installation.

#### BREATHER VALVE

13.8 x 2.4 mm O-RING

#### TANK CAP

#### BREATHER FILTER

##### INSTALLATION:

Clean the filter with water and neutral detergent and allow it to dry before installation.

#### CAP GASKET

#### INNER CAP

#### SPRING

8 mm WASHER

6 mm LOCK PIN

#### FUEL FILTER

##### INSTALLATION:

Remove any foreign material from the filter by blowing compressed air. Check the filter for damage before installation.

#### FUEL TANK

##### INSTALLATION:

Wash the fuel tank to remove water and foreign material accumulated in the tank.

**Tank capacity:**  
4.1 l (1.08 US gal, 0.90 Imp gal)

#### FUEL TUBE

##### INSTALLATION:

Check the tube not to be twisted when installed.

TUBE CLIP (C11)

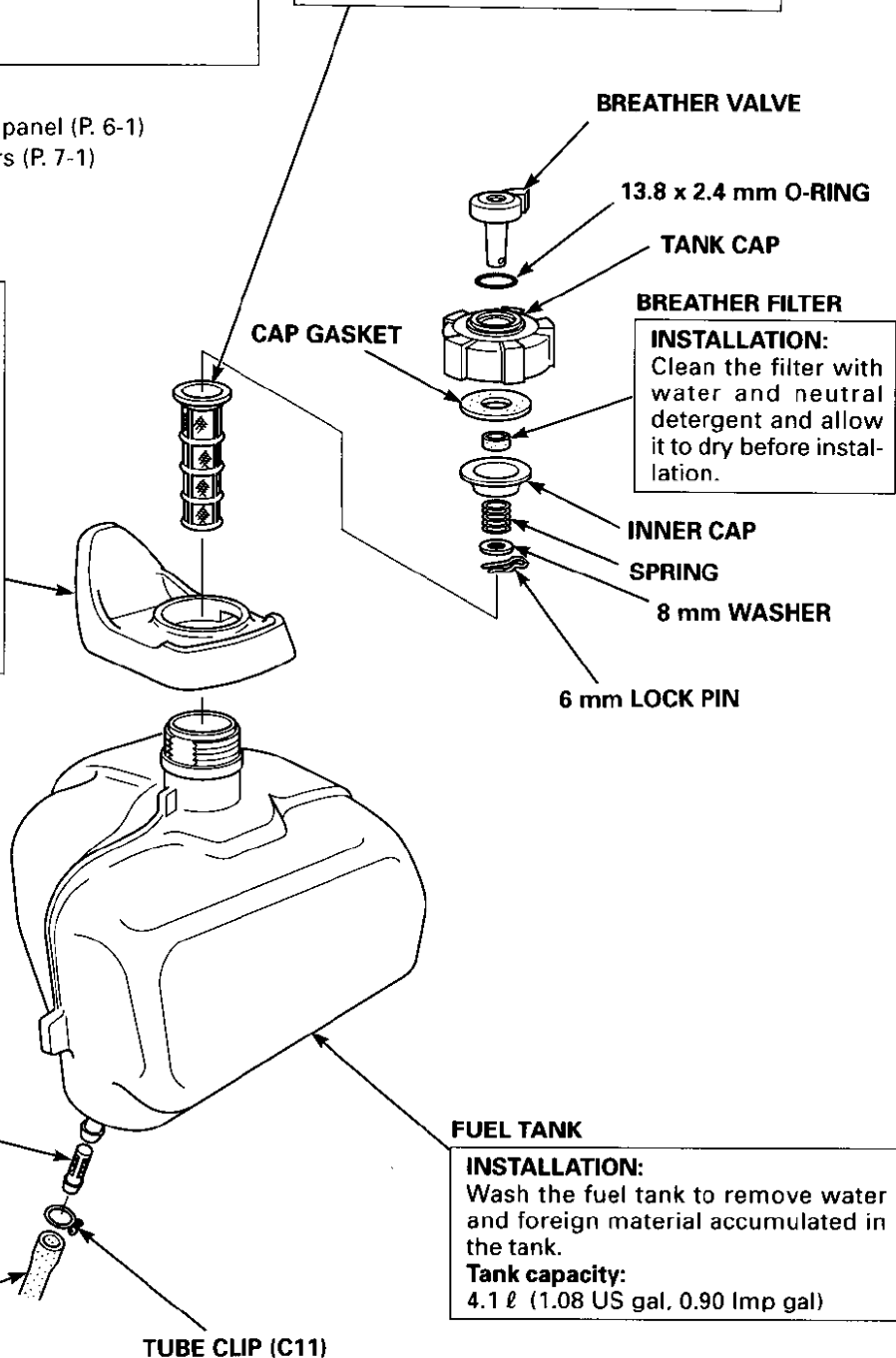

# EU2000i

## 3. FRONT FRAMES/UNDER COVER

### a. DISASSEMBLY/REASSEMBLY

- 1) Remove the rear cover (P. 4-1).
- 2) Remove the front cover and control panel (P. 6-1).
- 3) Remove the right and left side covers (P. 7-1).
- 4) Remove the fuel tank (P. 7-2).

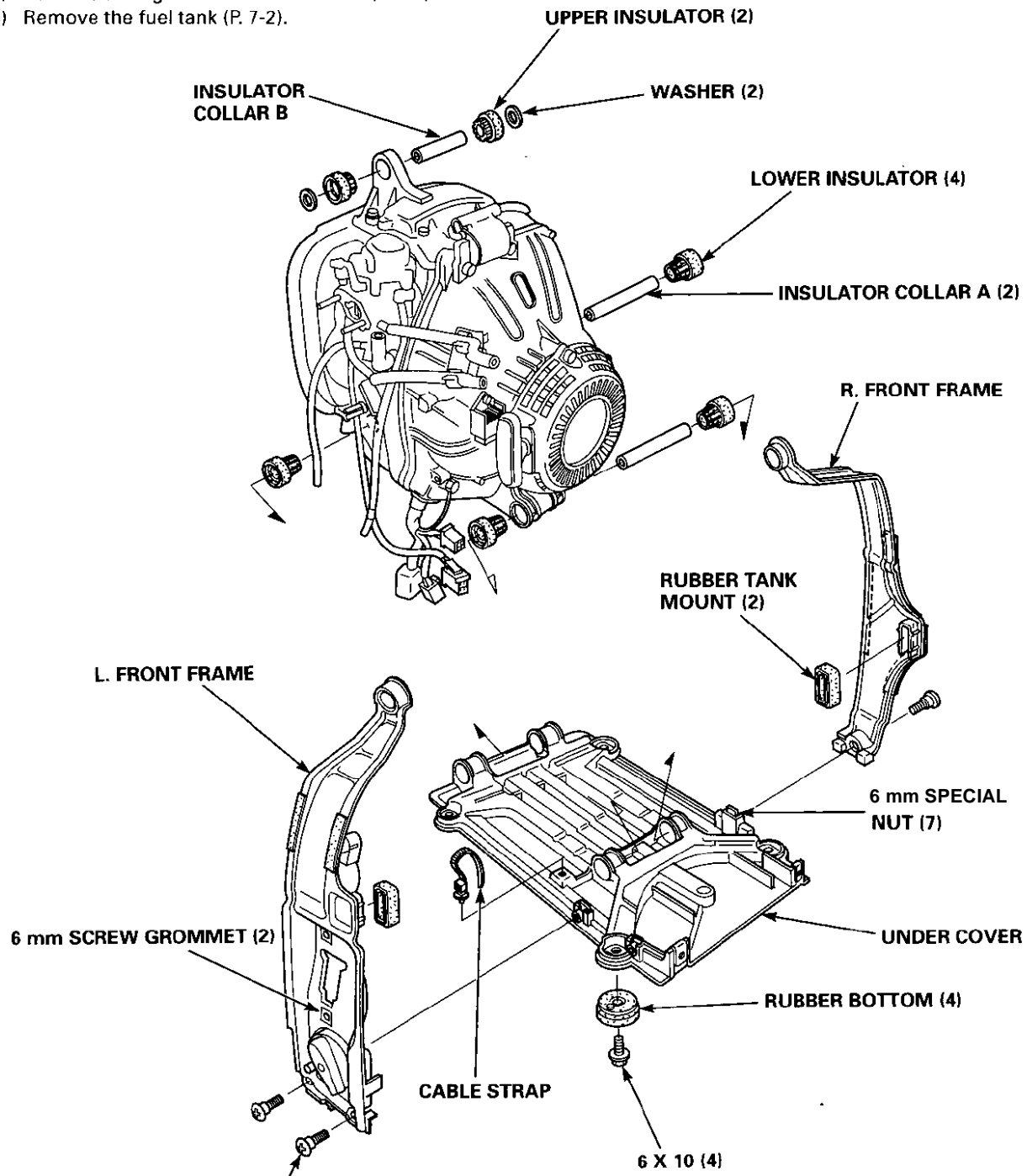

**6 x 15 mm SPECIAL SCREW (3)**  
 4.4 N•m (0.4 kg•f, 3.2 lbf•ft)



• **LEFT FRONT FRAME**

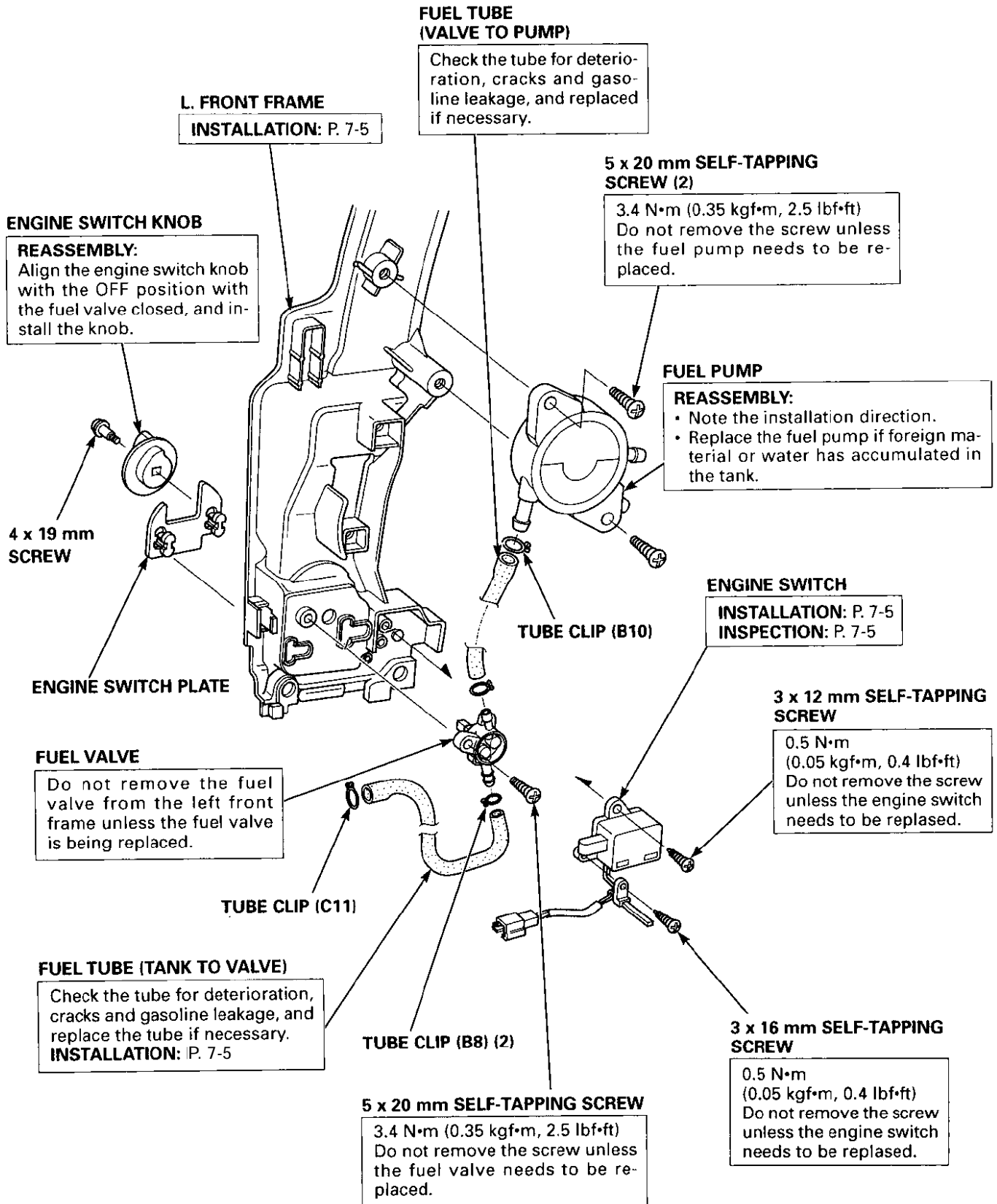

## EU2000i

### b. INSTALLATION

- 1) Check the harnesses and tubes of the left front frame for routing.

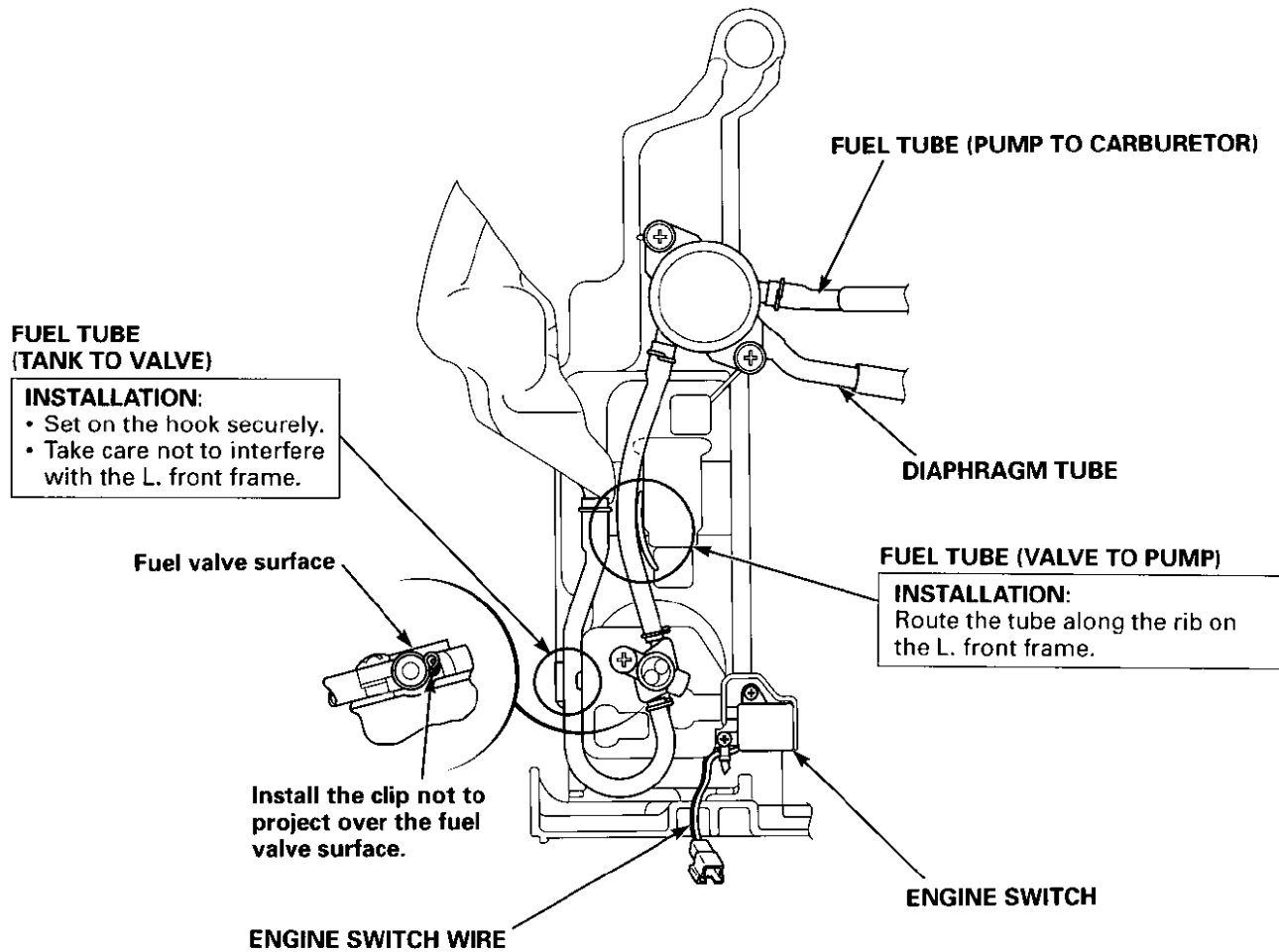

### c. INSPECTION

#### ● ENGINE SWITCH

Check for continuity between the switch terminals.

There must be no continuity with the switch turned ON, and there must be continuity with the switch turned OFF.

Check with the left side cover installed. Do not remove the engine switch unless it needs to be replaced.

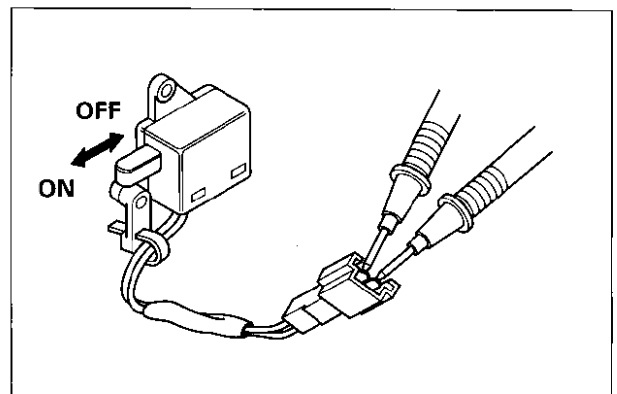



# 8. RECOIL STARTER/FAN COVER

1. RECOIL STARTER/FAN COVER.....	8-1	3. EXHAUST MANIFOLD/ CARBURETOR INSULATOR .....	8-6
2. FAN SHROUD .....	8-5		

## 1. RECOIL STARTER/FAN COVER

### a. DISASSEMBLY/REASSEMBLY

- 1) Remove the rear cover (P. 4-1).
- 2) Remove the front cover and control panel (P. 6-1).
- 3) Remove the right and left side covers (P. 7-1).
- 4) Remove the fuel tank (P. 7-2).
- 5) Remove the right and left front frames and under cover (P. 7-3).

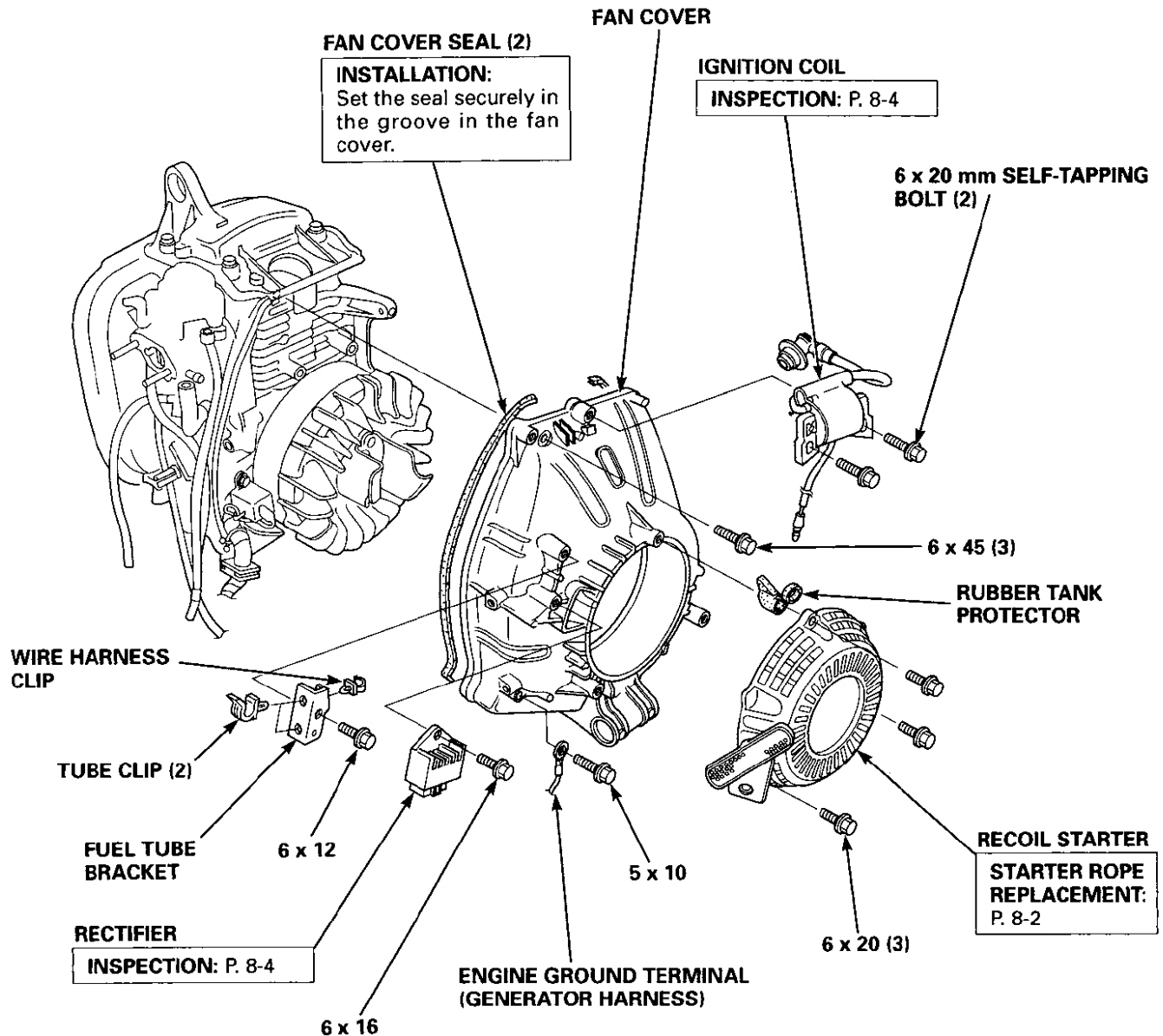

## b. STARTER ROPE REPLACEMENT

- 1) Pull the starter grip fully (until the starter rope is pulled out fully.)

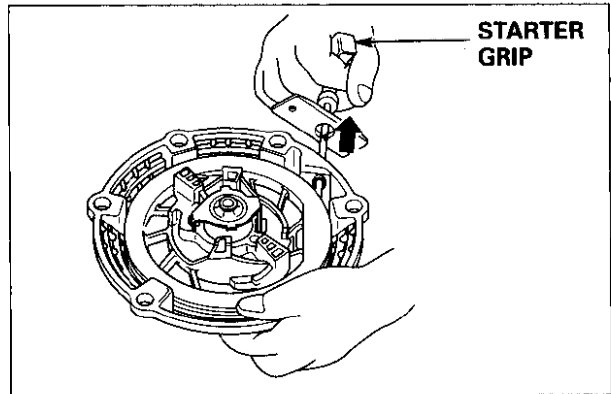

- 2) To prevent the starter reel from rewinding, hold the starter reel and starter case with a band or equivalent material as shown.
- 3) Remove the grip cover by inserting a bar from the hole in the grip to route the starter rope and pushing it.
- 4) Untie the knots of the starter rope at the starter grip side and the starter reel side, and remove the starter rope.

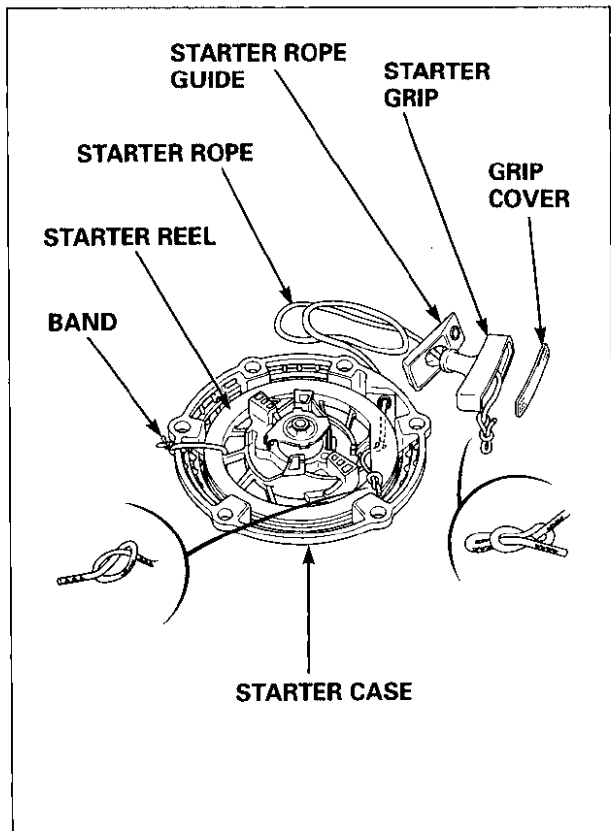

- 5) When the starter rope has broken or the starter reel has rewound, align the rope hole in the starter case with the rope hole in the starter reel by turning the starter reel 5 turns in the direction of the arrow.

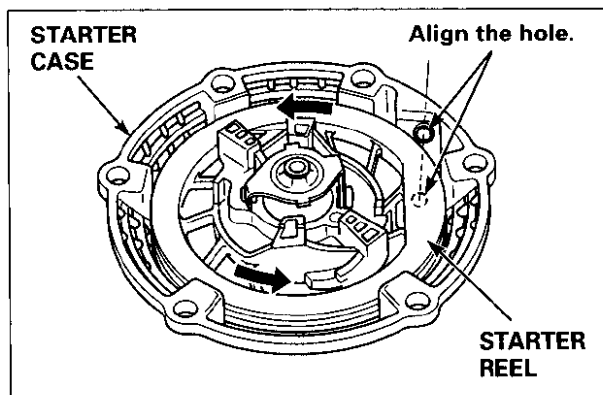

**EU2000i**

- 6) Make a knot at the ends of the starter rope, i. e. at the reel side end and the starter grip side end, as shown at 15 mm (0.6 in) from the ends of the rope.

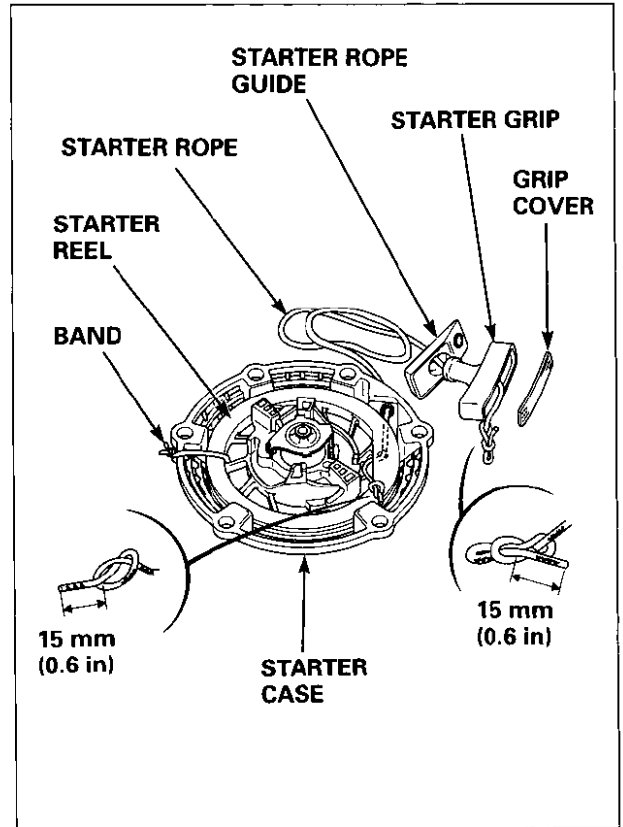

- 7) Wind the starter rope slowly on the starter reel.
- 8) Check the operation of the ratchet by pulling the starter rope several times.

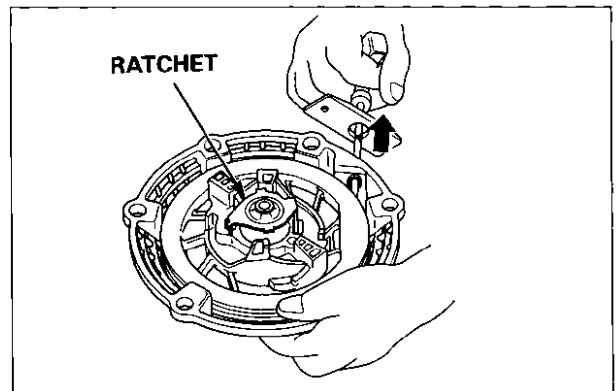

### c. INSPECTION

#### ● RECTIFIER

Check for continuity between the terminals according to the table below.

Tester lead (+)	1	2	3	4
Tester lead (-)				
1		$\infty$	$\infty$	$\infty$
2	Continuity		Continuity	Continuity
3	Continuity	$\infty$		$\infty$
4	Continuity	$\infty$	$\infty$	

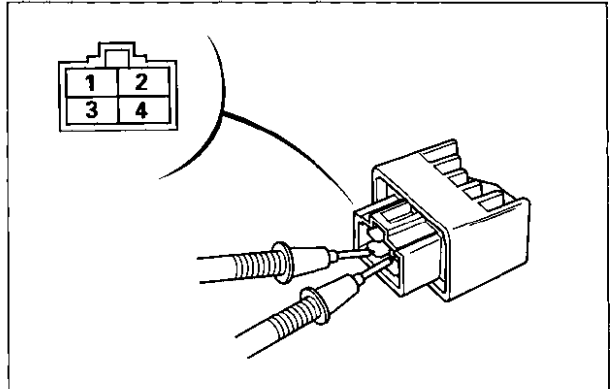

#### ● IGNITION COIL

##### <Primary resistance>

Attach one lead of the tester to the lead wire terminal and another tester lead to the iron core, and measure the primary resistance of the ignition coil.

Resistance	0.7 – 1.1 $\Omega$
------------	--------------------

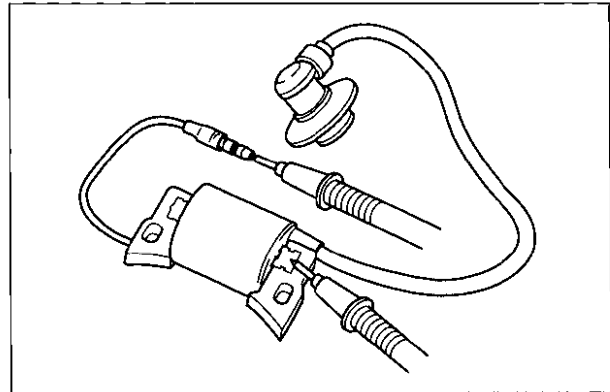

##### <Secondary resistance>

Attach one lead of the tester to the terminal inside the spark plug cap and another lead to the iron core, and measure the secondary resistance of the ignition coil.

Resistance	12 – 21 k $\Omega$
------------	--------------------

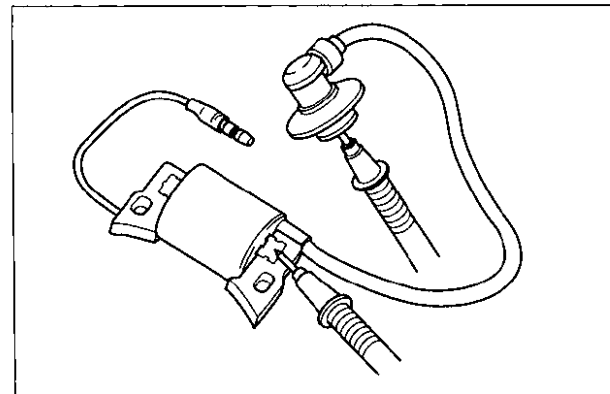

**EU2000i****2. FAN SHROUD****a. DISASSEMBLY/REASSEMBLY**

- 1) Remove the rear cover (P. 4-1).
- 2) Remove the front cover and control panel (P. 6-1).
- 3) Remove the right and left side covers (P. 7-1).
- 4) Remove the fuel tank (P. 7-2).
- 5) Remove the right and left front frames and under cover (P. 7-3).
- 6) Remove the recoil starter and fan cover (P. 8-1).

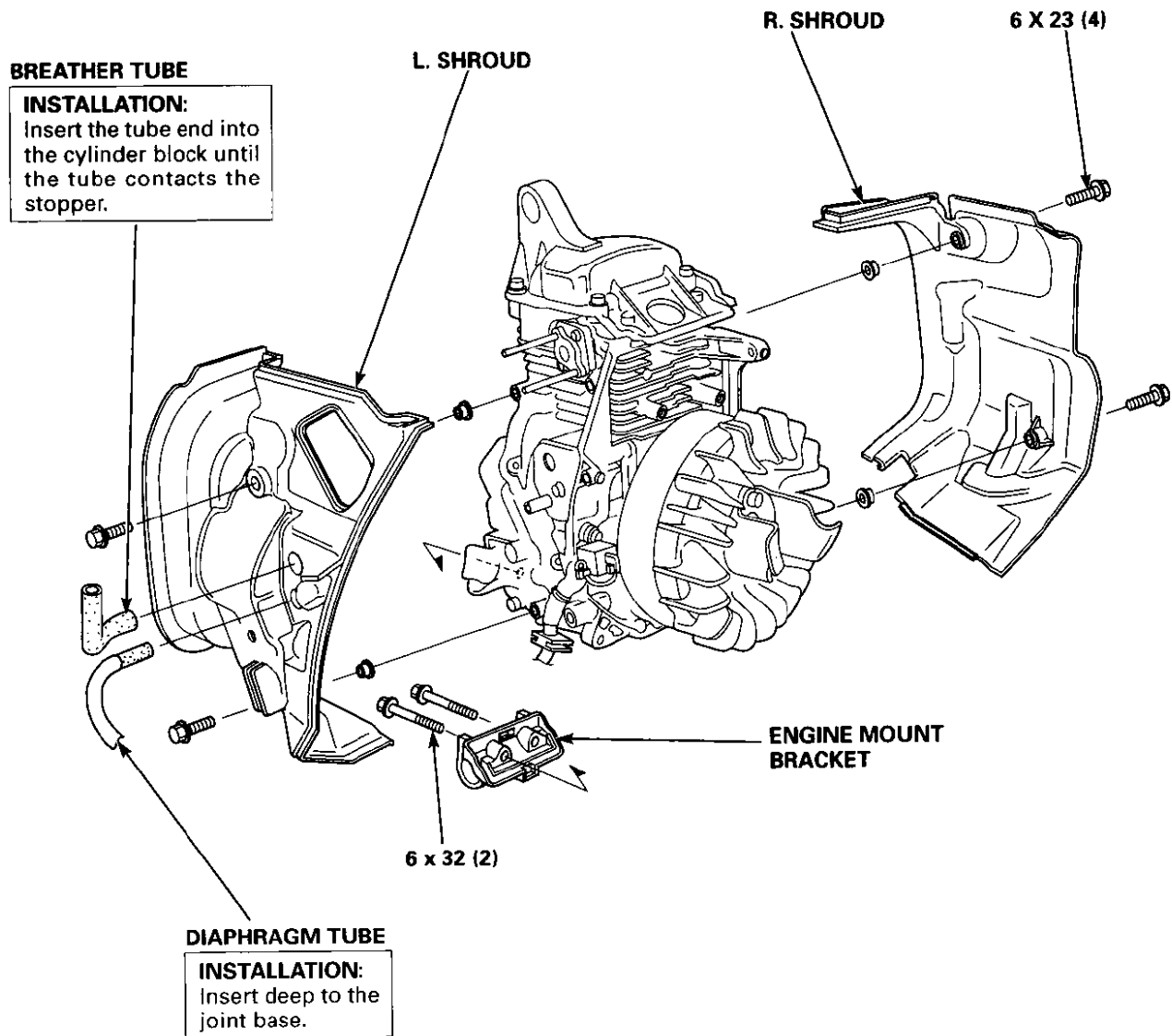



### 3. EXHAUST MANIFOLD/CARBURETOR INSULATOR

#### a. DISASSEMBLY/REASSEMBLY

1) Remove the fan shroud (P. 8-5).

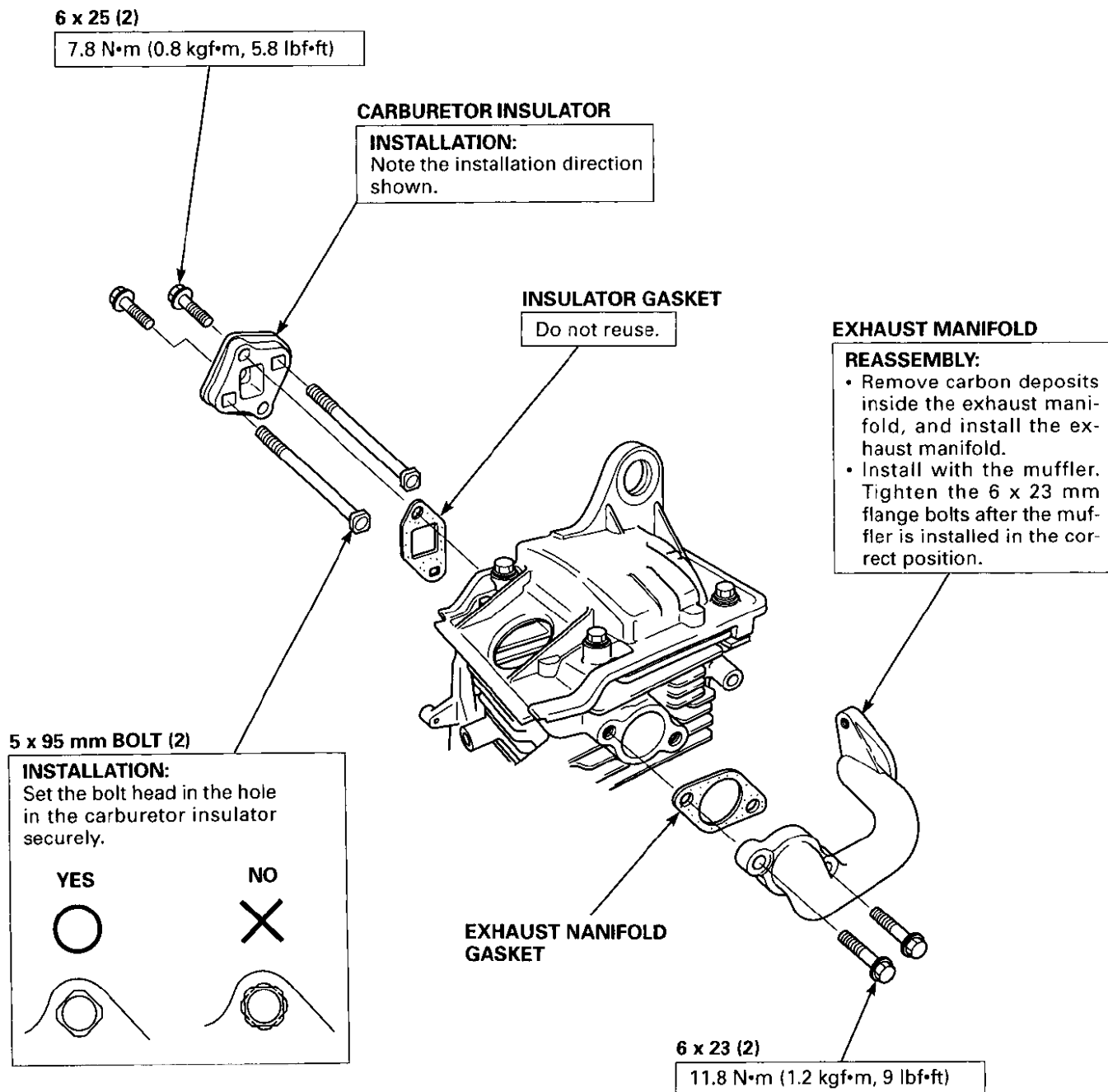

# 9. GENERATOR

## EU2000i

1. GENERATOR .....	9-1	2. BREATHER COVER A/B .....	9-5
--------------------	-----	-----------------------------	-----

### 1. GENERATOR

#### a. DISASSEMBLY/REASSEMBLY

- 1) Remove the rear cover (P. 4-1).
- 2) Remove the front cover and the control panel (P. 6-1).
- 3) Remove the right and left side covers (P. 7-1).
- 4) Remove the fuel tank (P. 7-2).
- 5) Remove the front frames and under cover (P. 7-3).
- 6) Remove the recoil starter and fan cover (P. 8-1).

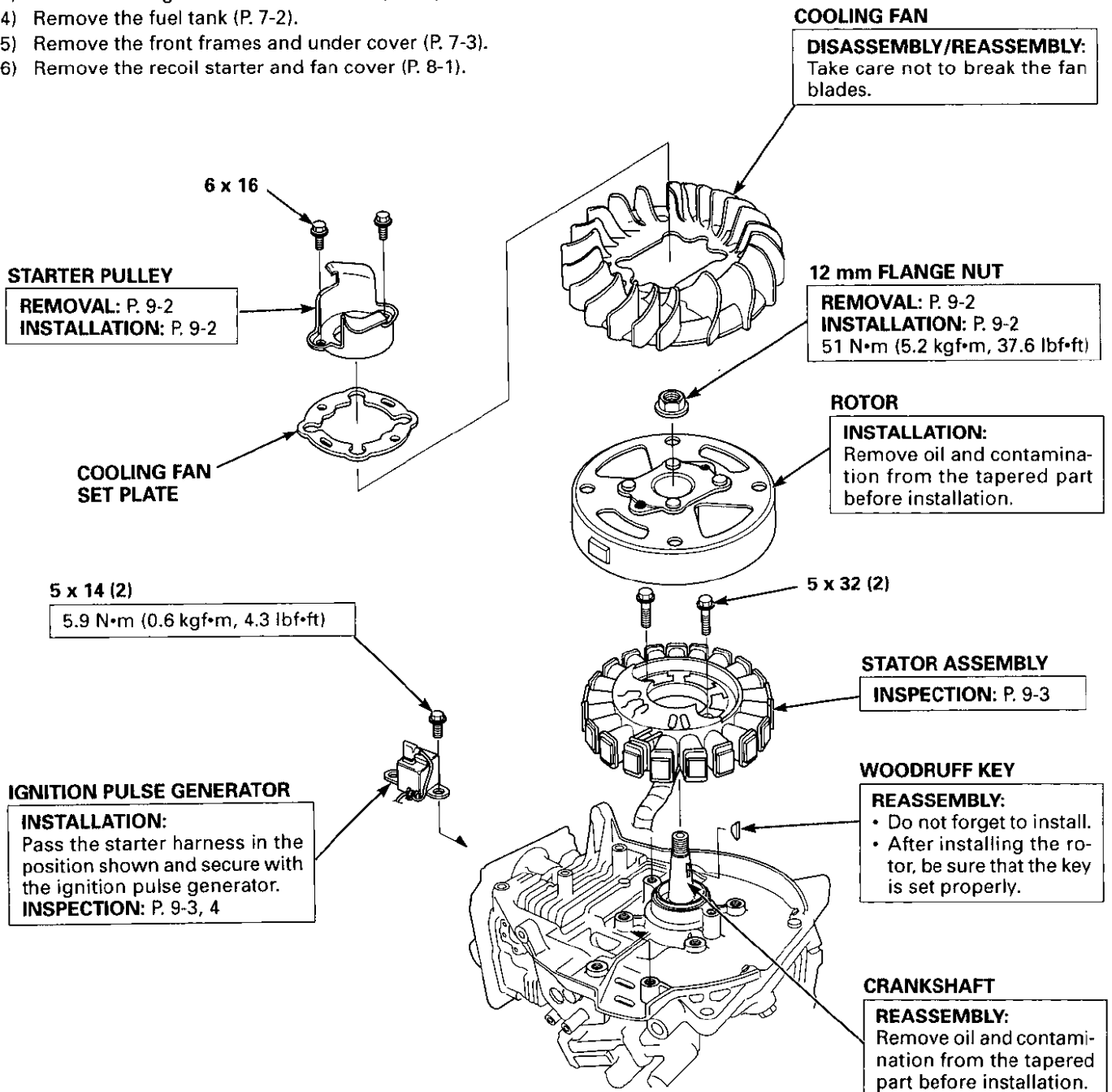

## ● ROTOR REMOVAL

- 1) Remove the ignition pulse generator (P. 9-1).
- 2) Holding the rotor on the corner with a commercially available strap wrench, remove the two 6 x 16 mm flange bolts, and remove the recoil starter pulley, cooling fan set plate and cooling fan.
- 3) Holding the rotor on the corner with a commercially available strap wrench, remove the 12 mm flange nut.

### NOTICE

*Do not try to remove the nut by striking it with a hammer or equivalent tool.*

- 4) Remove the rotor using the flywheel puller.

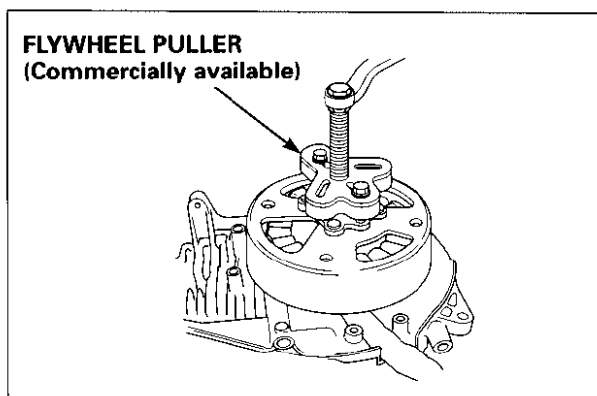
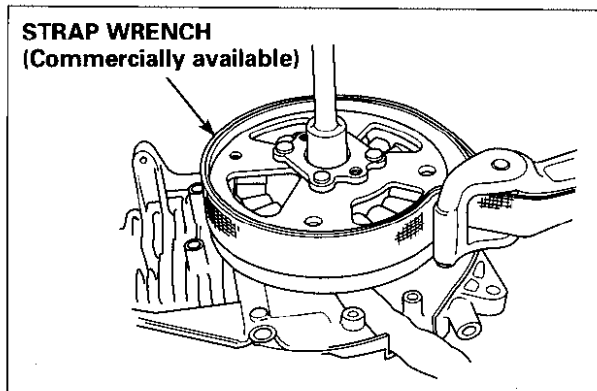

## ● ROTOR INSTALLATION

- 1) Remove the dust and oil from the tapered part of the crankshaft and rotor.
- 2) Set the woodruff key in the key groove securely.
- 3) Install the rotor on the crankshaft. Check to see whether the magnetic part of the rotor is free from metallic particles, washers, etc.
- 4) Holding the rotor on the corner with a commercially available strap wrench, tighten the 12 mm flange nut to the specified torque.

**TORQUE: 51 N·m (5.2 kgf·m, 37.6 lbf·ft)**

- 5) Install the cooling fan, cooling fan set plate and recoil starter pulley.
- 6) Holding the rotor on the corner with a commercially available strap wrench, tighten the two 6 x 16 mm flange bolts.
- 7) Install the ignition pulse generator.

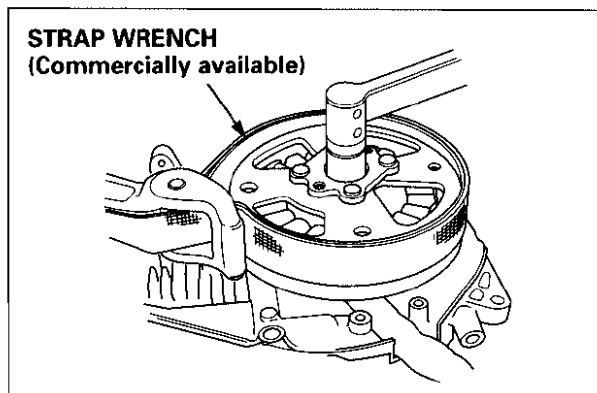

## EU2000i

### b. INSPECTION

#### ● IGNITION PULSE GENERATOR

Measure the resistance between the terminals A and B shown.

Resistance	300 – 360 $\Omega$
------------	--------------------

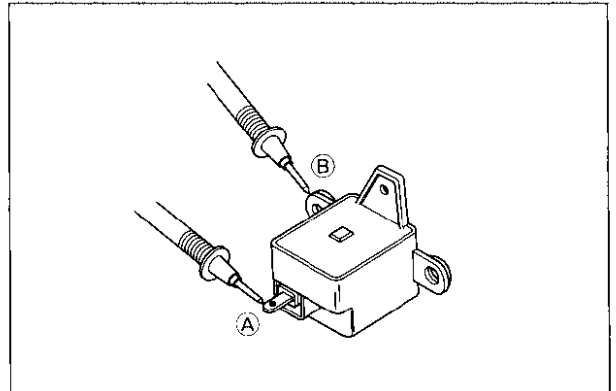

#### ● STATOR

##### Exciter coil:

Measure the resistance between the black/blue terminal and stator core.

- If the resistance is measured with stator mounted on the generator, disconnect the small 6P connector, measure the resistance between the black/blue terminal and the green terminal.

Resistance	0.2 – 0.3 $\Omega$
------------	--------------------

If the resistance is out of the specification, inspect the generator wire harness. Replace the generator wire harness if necessary.

If the generator wire harness is normal, replace the stator assembly.

##### Sub coil:

Measure the resistance between the orange and gray terminals of the big 6P connector.

Resistance	0.1 – 0.2 $\Omega$
------------	--------------------

If the resistance is outside the specification, inspect the generator wire harness. Replace the generator wire harness if necessary.

If the generator wire harness is normal, replace the stator assembly.

##### AC coil:

Measure the resistance between the red, white and blue terminals of the big 6P connector.

Resistance	Red – white: 1.4 – 1.5 $\Omega$ Red – blue: 1.4 – 1.5 $\Omega$ White – blue: 1.4 – 1.5 $\Omega$
------------	---

If the resistance is out of the specification, inspect the generator wire harness. Replace the generator wire harness if necessary.

If the generator wire harness is normal, replace the stator assembly.

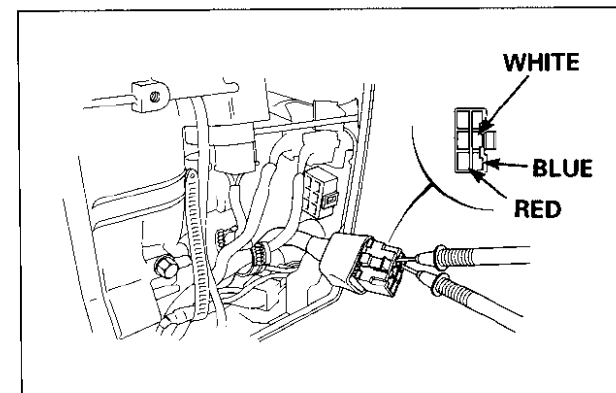
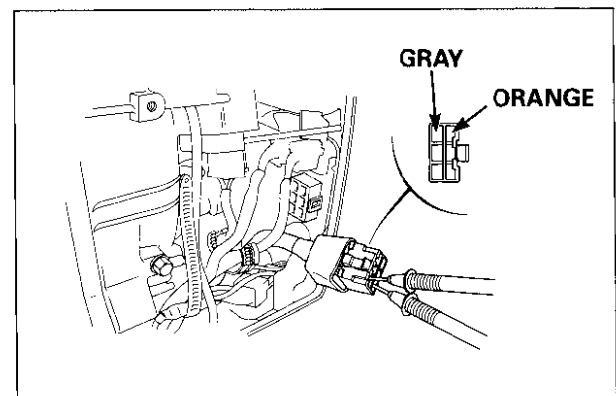
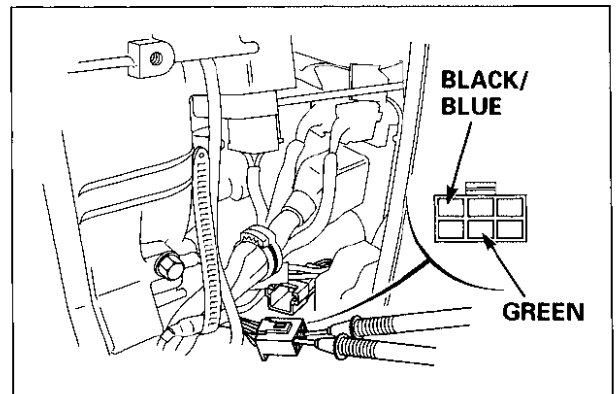

**DC coil:**

Measure the resistance between the terminals of the 4P connector.

Resistance	0.1 – 0.2 $\Omega$
------------	--------------------

If the resistance is out of the specification, inspect the generator wire harness. Replace the generator wire harness if necessary.

If the generator wire harness is normal, replace the stator assembly.

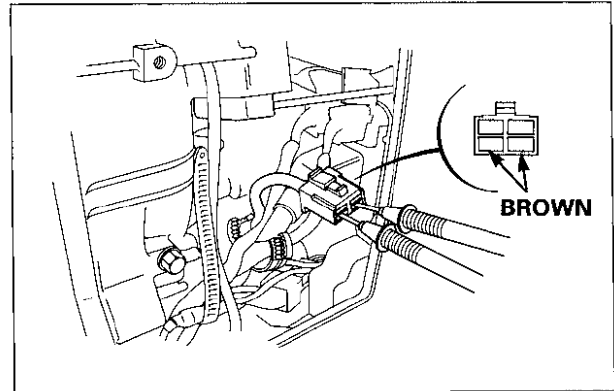

• **IGNITION PULSE GENERATOR-TO-ROTOR CLEARANCE**

Insert a feeler gauge between the ignition pulse generator and the rotor projection and inspect the air gap.

Air gap	0.2 – 0.7 mm (0.008 – 0.028 in)
---------	---------------------------------

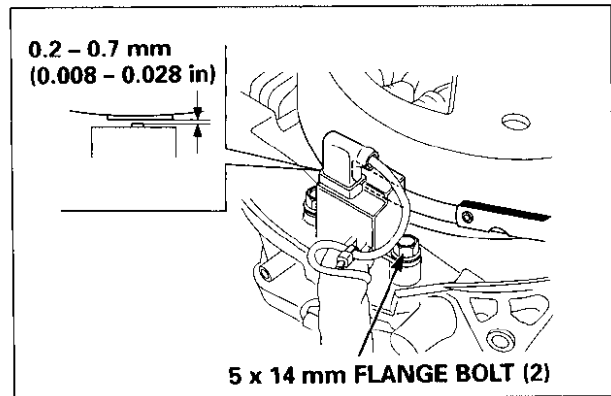

# EU2000i

## 2. BREATHER COVER A/B

### a. DISASSEMBLY/REASSEMBLY

#### BREATHER COVER A:

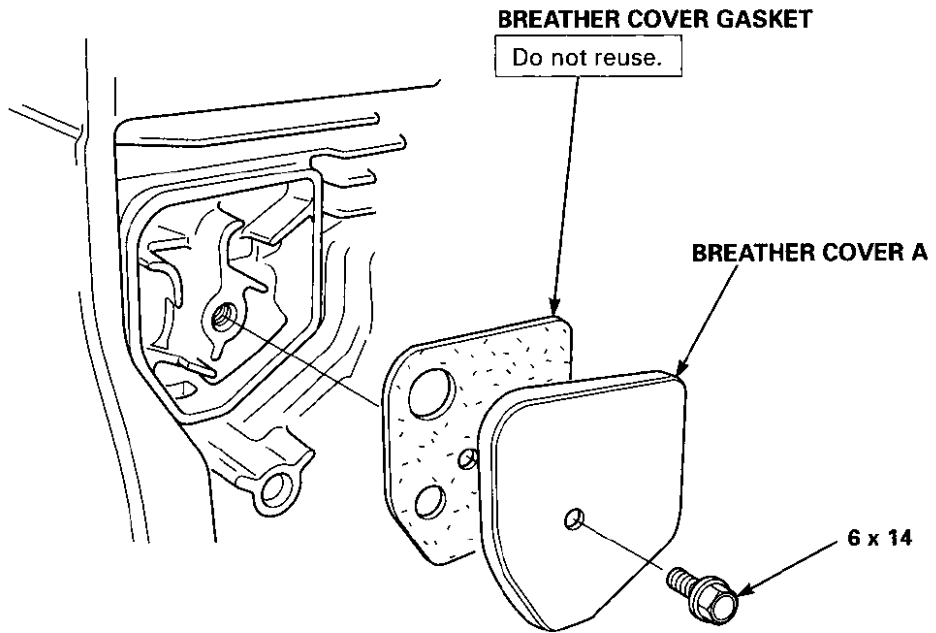

#### BREATHER COVER B:

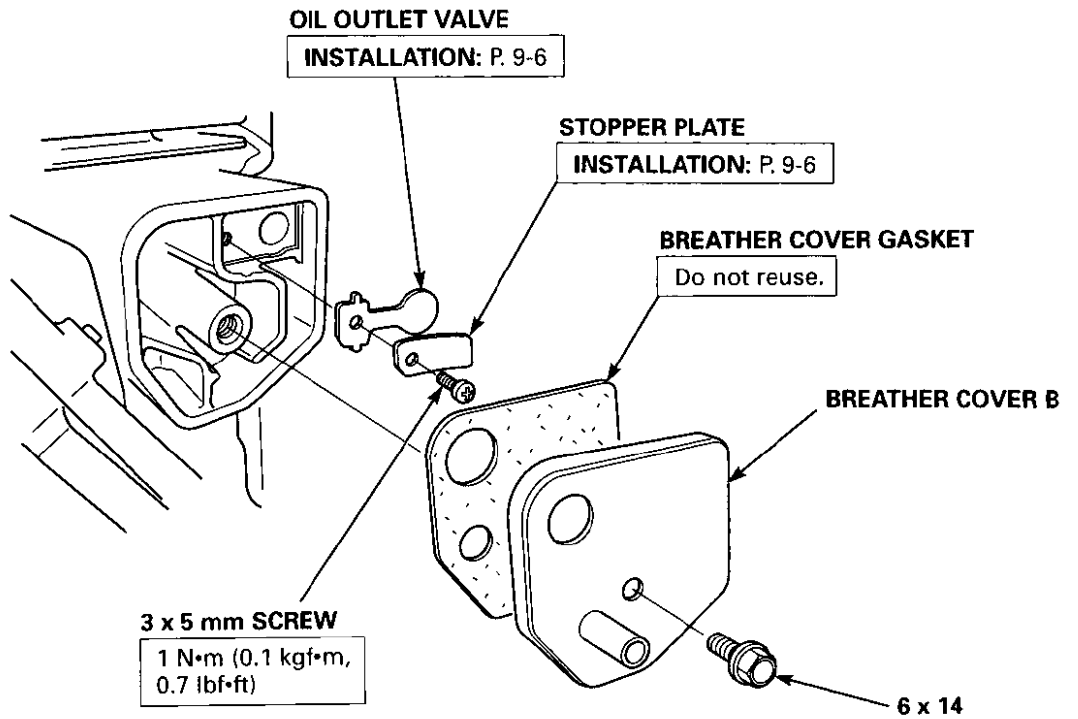

## ● OUTLET VALVE/STOPPER PLATE

### INSTALLATION:

- 1) Clean the oil outlet valve, stopper plate and the valve installation area of the cylinder block.
- 2) Install the valve aligning the positioning projections and chamfer of the valve with the groove and chamfer of the cylinder block.
- 3) Install the stopper plate on the valve aligning the chamfer of the stopper plate with the chamfer of the cylinder block.
- 4) Tighten the 3 x 5 mm screw securely.

**TORQUE: 1 N·m (0.1 kgf·m, 0.7 lbf·ft)**

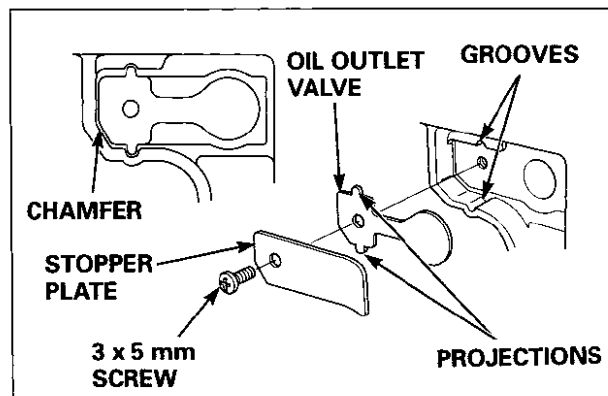

# 10. CAM PULLEY/CRANKSHAFT/ PISTON/CYLINDER BLOCK

## EU2000i

1. CAM PULLEY .....	10-1	5. GOVERNOR.....	10-14
2. CRANKCASE COVER/ CRANKSHAFT/CYLINDER BLOCK..	10-5	6. INSPECTION.....	10-17
3. PISTON .....	10-10	7. VALVE GUIDE REPLACEMENT .....	10-24
4. VALVES .....	10-12	8. VALVE SEAT RECONDITIONING .....	10-26

## 1. CAM PULLEY

### a. REMOVAL/INSTALLATION

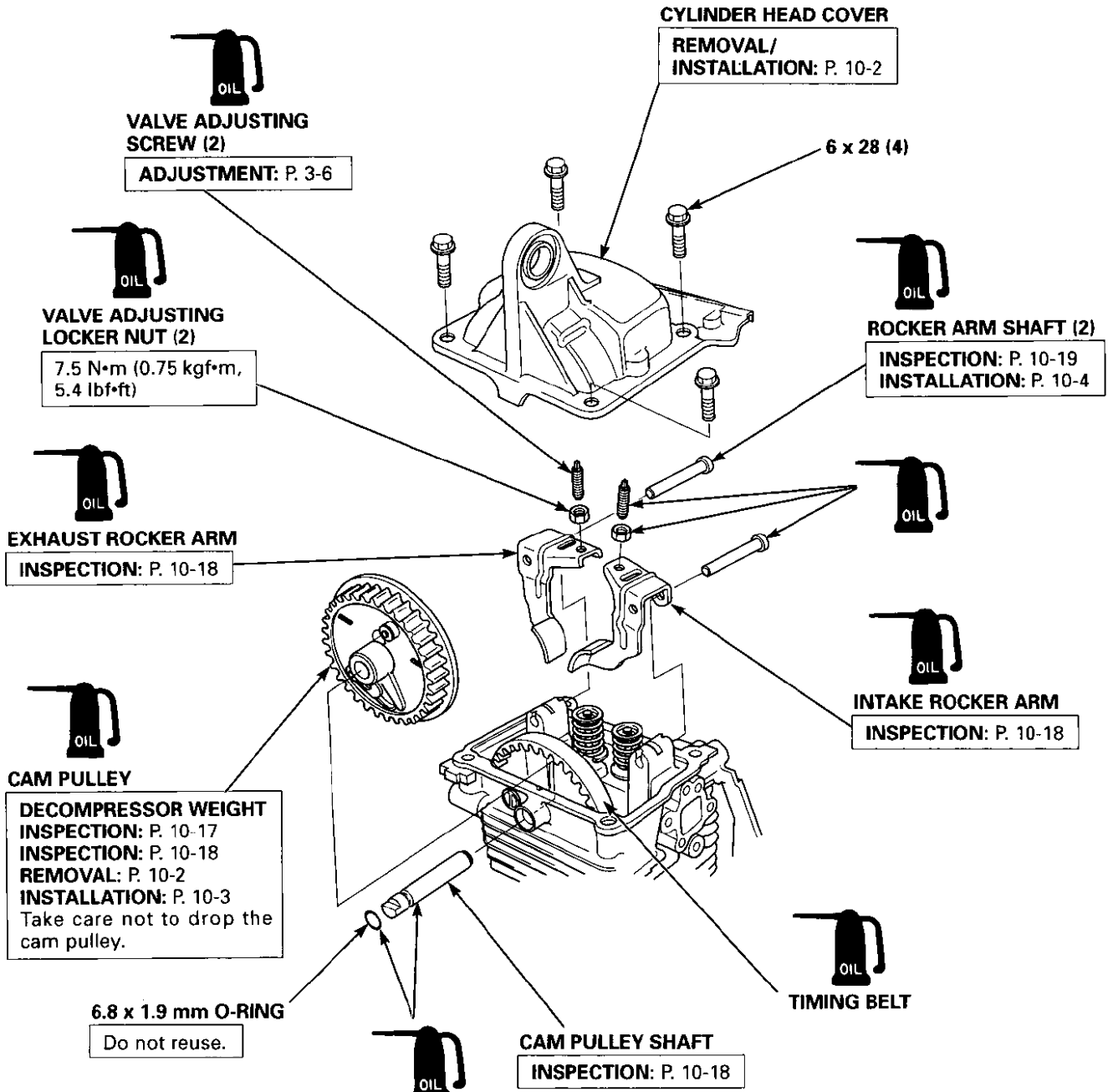



## ● HEAD COVER

### REMOVAL:

- 1) Remove the four 6 x 28 mm flange bolts.
- 2) To remove the head cover, insert a screwdriver or equivalent tool into the cylinder recess as shown. Remove the head cover slowly.
  - Clean up any spilled engine oil with a shop towel when removing the head cover.

### NOTICE

- Do not remove the head cover with force, because that can deform the head cover.
- Replace the head cover if it is deformed.

### INSTALLATION:

- 1) Clean the mating surfaces of the head cover and the cylinder using a degreasing cleaning agent or a clean shop towel.
- 2) Apply a 1.5 – 2.0 mm (0.06 – 0.08 in) diameter bead of liquid gasket (Hondabond #4, ThreeBond #1207B or equivalent) to the cylinder block. Specifically, to the inner wall of the groove and bolt holes in the cylinder block.

Assemble within 10 minutes after applying the liquid gasket.

- 3) Wait for approximately 20 minutes after assembly before filling with oil and starting the engine.

## ● CAM PULLEY

### REMOVAL:

- 1) Remove the spark plug and head cover.
- 2) Put the piston at top dead center (TDC) of the compression stroke where both valves are fully closed. The top dead center of the compression stroke is in the position where the head cover mating surface is in line with the cam pulley alignment marks.
- 3) Remove the intake and exhaust rocker arms and the rocker arm pins (P. 10-1).

Remove the cam pulley shaft from the cam pulley (P. 10-1).

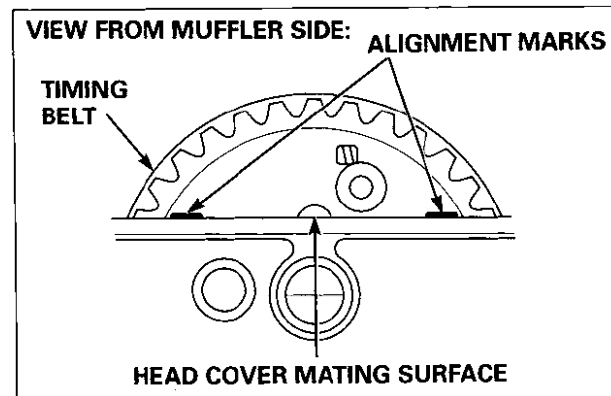
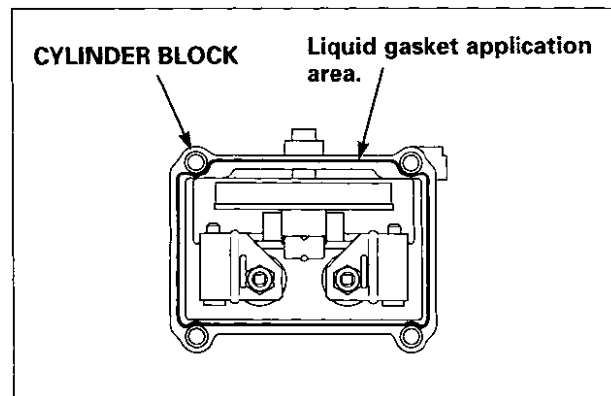
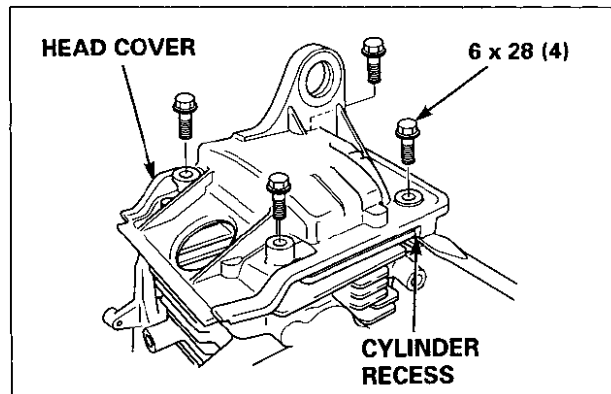

**EU2000i**

- 4) Push the cam pulley into the cylinder a little. Detach the timing belt from the flange side of the cam pulley as shown, and remove the cam pulley.

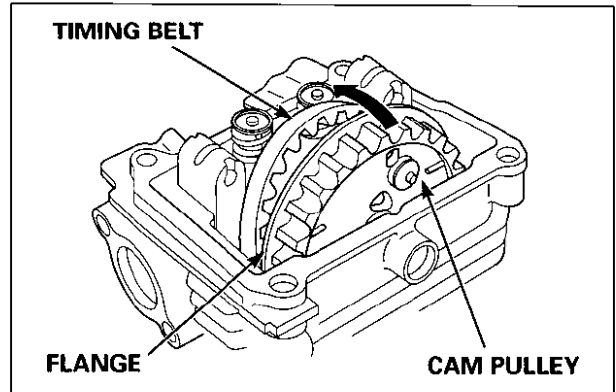
**INSTALLATION:**

- 1) Put the piston at top dead center (TDC) of the compression stroke where both valves are fully closed. Align the starter pulley alignment point with the fan cover "▲" mark.

The top dead center of the compression stroke is in the position where the head cover mating surface is in line with the cam pulley alignment marks.

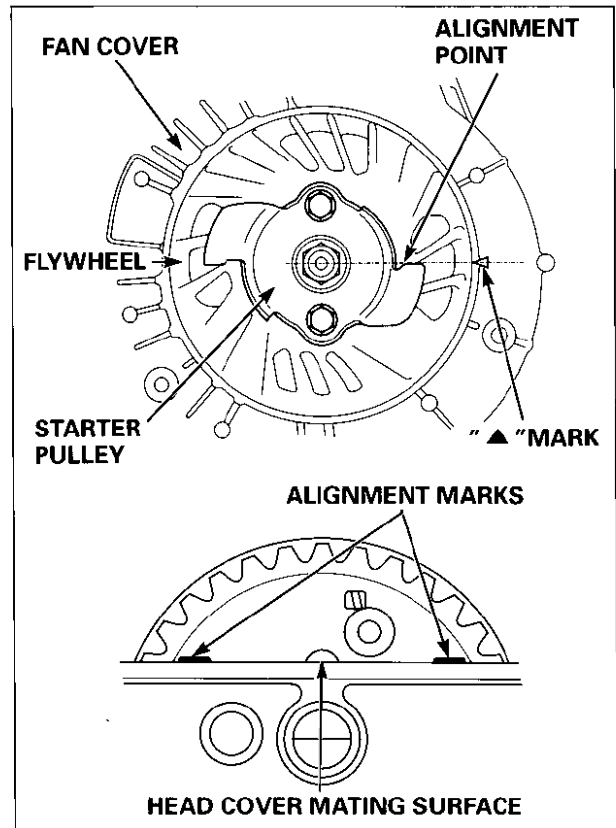

- 2) Set the timing belt on the cam pulley from the flange side of the cam pulley.

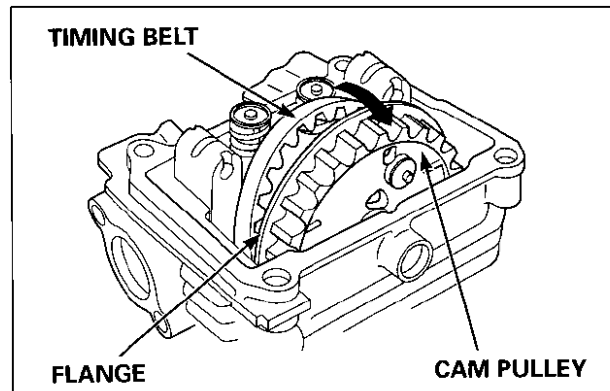

- 3) Align the alignment marks on the cam pulley so that they are in line with the head cover mating surface.

The top dead center of the compression stroke is in the position where the head cover mating surface is in line with the cam pulley alignment marks.

Be careful to avoid turning the crankshaft when installing.

- 4) Apply oil to the 6.8 x 1.9 mm O-ring and install it on the cam pulley shaft (P. 10-1).
- 5) Install the cam pulley shaft in the cylinder (P. 10-1).
- 6) Holding the cam pulley alignment marks in line with the head cover mating surface, check again whether the piston is at the top dead center of the compression stroke.
- 7) If the alignment marks and the head cover mating surface are out of alignment or if the piston is not at the top dead center of the compression stroke, repeat the procedure from the step 1 (P. 10-3).

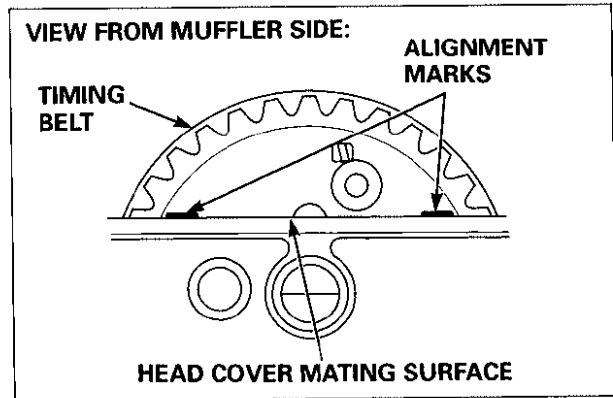

## ● ROCKER ARM SHAFT

### INSTALLATION:

Install the rocker arm shaft from the opposite side of the cam pulley as shown.

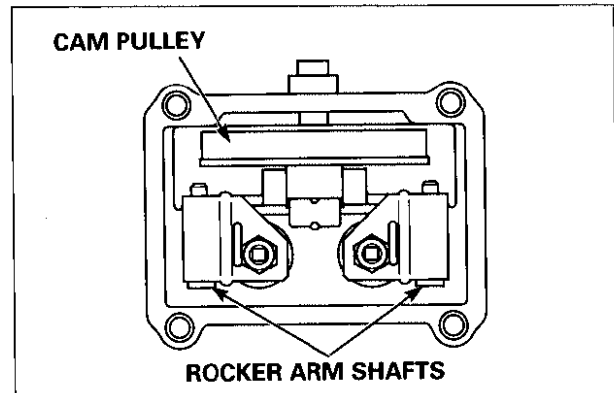

# EU2000i

## 2. CRANKCASE COVER/CRANKSHAFT/CYLINDER BLOCK

### a. REMOVAL/INSTALLATION

Remove the cam pulley and rocker arm (P. 10-1).

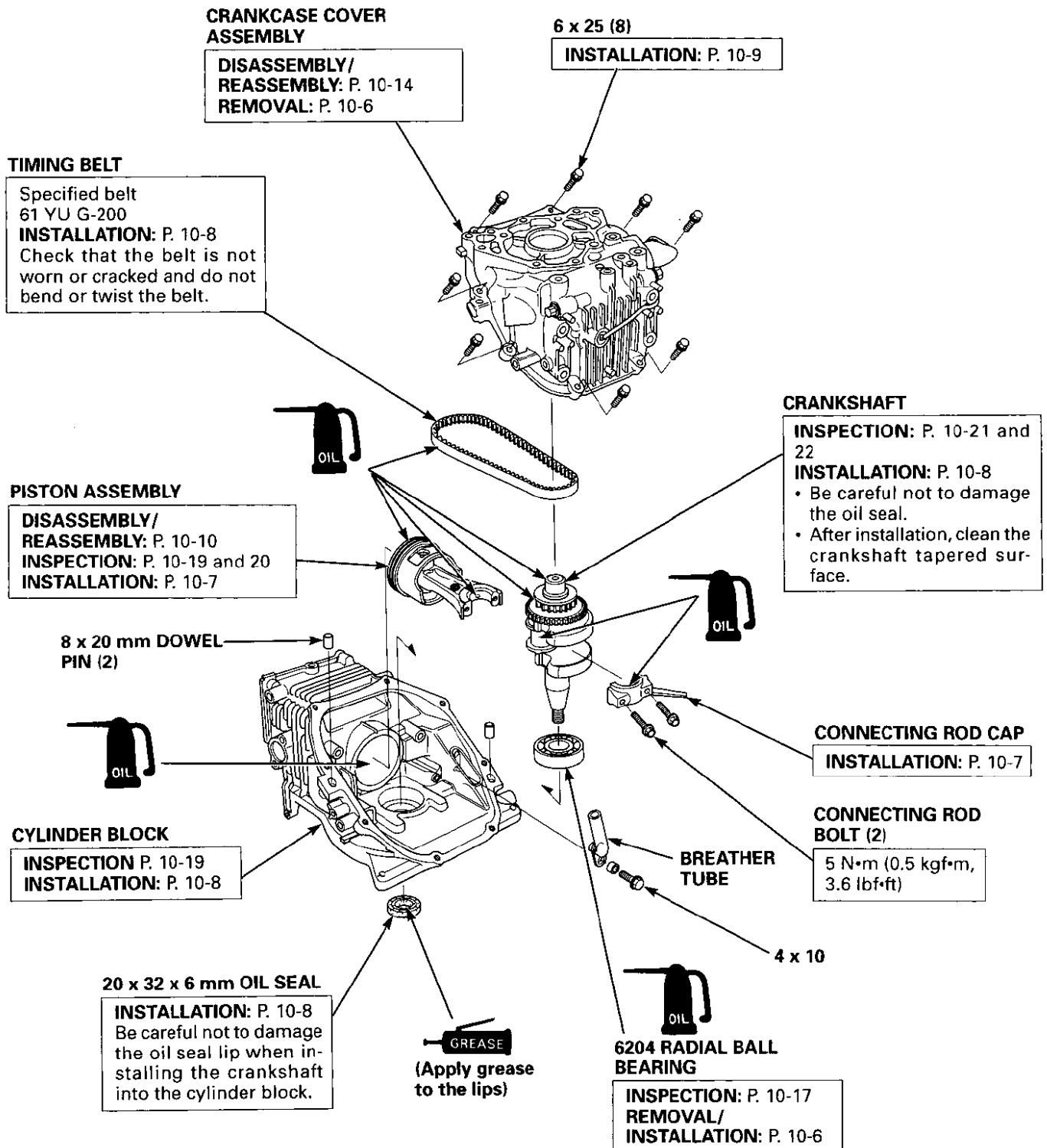

### ● CRANKCASE COVER ASSEMBLY

#### REMOVAL:

- 1) Remove the eight 6 x 25 mm flange bolts.
- 2) Insert a screw driver or equivalent tool into the recess as shown, and remove the crankcase cover from the cylinder block.

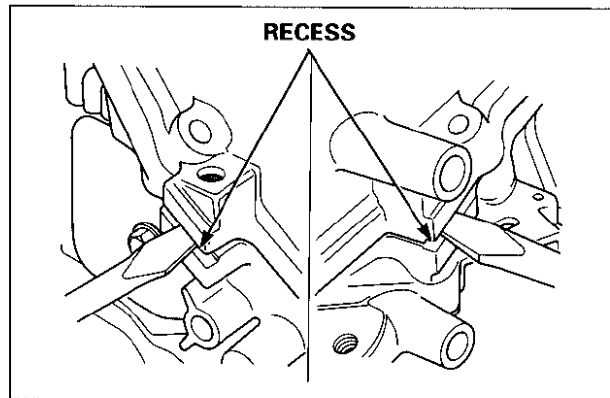

### ● 6204 RADIAL BALL BEARING

#### REMOVAL:

Pull the bearing off the crankshaft, using a commercially available bearing puller.

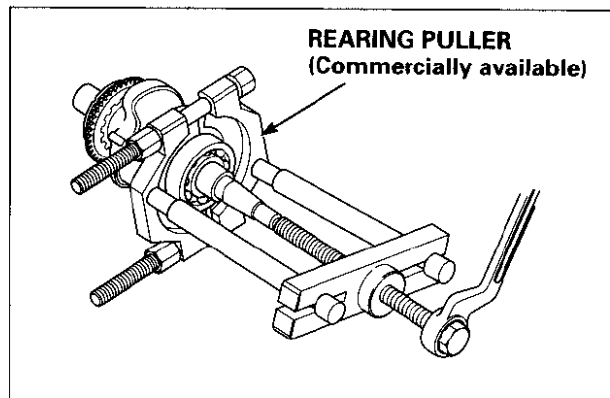

#### INSTALLATION:

- 1) Apply oil to the circumference of a new radial ball bearing.
- 2) Press the radial ball bearing onto the crankshaft, using the special tools.

#### TOOLS:

Driver, 22 mm I.D.  
Attachment 20 mm I.D.

07746-0020100  
07746-0020400

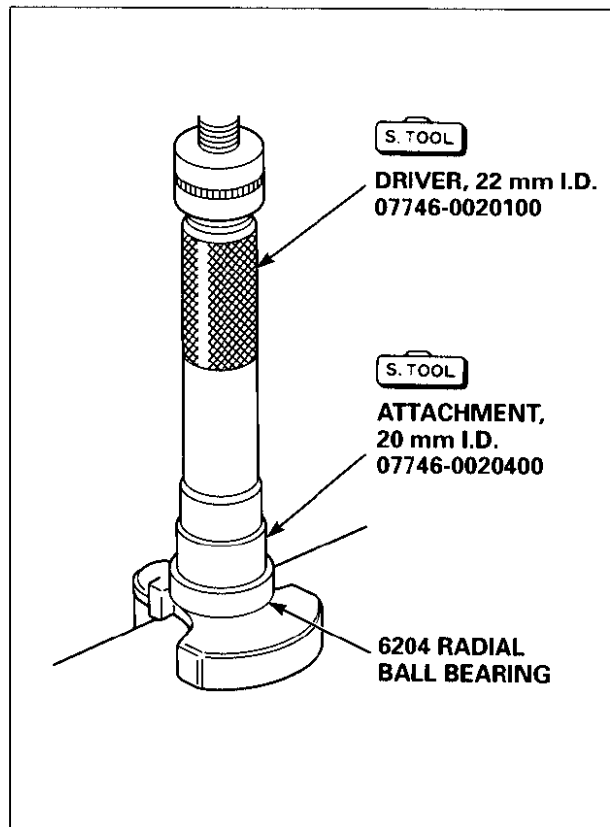

## EU2000i

### ● PISTON ASSEMBLY/CONNECTING ROD CAP

#### INSTALLATION:

- When the piston and connecting rod are disassembled, check that the piston is properly assembled with the connecting rod. Assemble the piston and connecting rod properly if necessary (P. 10-11).
  - Perform the following after checking that the piston and connecting rod are installed properly.
- 1) Apply oil to the inner wall of the cylinder, outer surface of the piston and to the inner wall of the connecting rod big end.
  - 2) Install the piston assembly in the cylinder block with the cam pulley mounting part toward up. Be sure that the "▼" mark of the "FW ▼" mark on the piston skirt inside points down (toward the flywheel) when the longer side of the connecting rod long end is facing to the right as shown.

The piston must be at the top dead center of the compression stroke.

- Take care not to break the piston ring when installing the piston assembly in the cylinder.

- 3) Apply oil to the crank pin and journal.
- 4) Install the crankshaft in the cylinder block (P. 10-5).
- 5) Apply oil to the connecting rod cap bearing.
- 6) Install by aligning the alignment marks on the connecting rod big end and connecting rod cap.
- 7) Apply oil to the threaded part and seat of the connecting rod bolts. Tighten the connecting rod bolts to the specified torque.

**TORQUE: 5 N·m (0.5 kgf·m, 3.6 lbf·ft)**

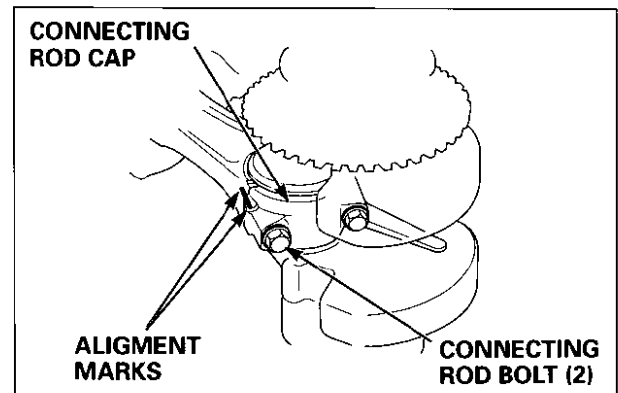
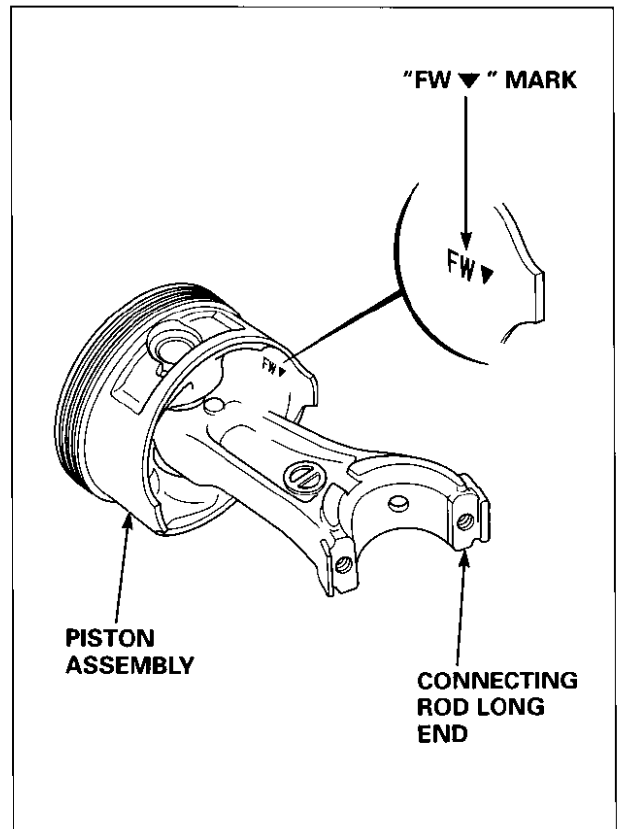

### ● 20 x 32 x 6 mm OIL SEAL

#### INSTALLATION:

<Cylinder block side>

- 1) Apply oil to the outside of the new oil seal.
- 2) Install the new oil seal on the cylinder block using the special tools as shown.

#### TOOLS:

Driver	07749-0010000
Attachment, 32 x 35 mm	07746-0010100
Pilot, 20 mm	07746-0040500

- 3) After installation, apply grease to the lip.

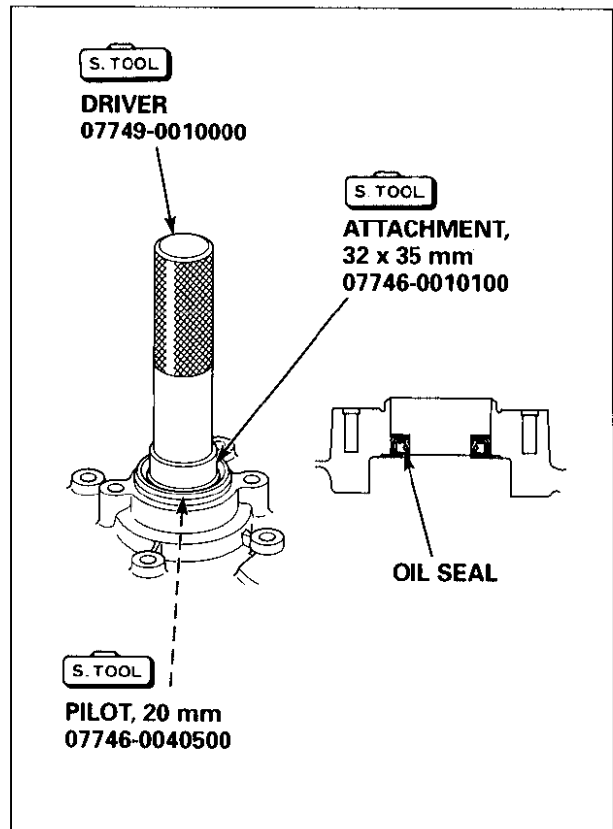

### ● CRANKSHAFT/CYLINDER BLOCK/TIMING BELT/6 X 25 mm FLANGE BOLT

#### INSTALLATION:

- 1) Install the piston/connecting rod assembly in the cylinder block (P. 10-5).
- 2) Align the "■" mark on the cylinder block with the "■" mark on the crankshaft.

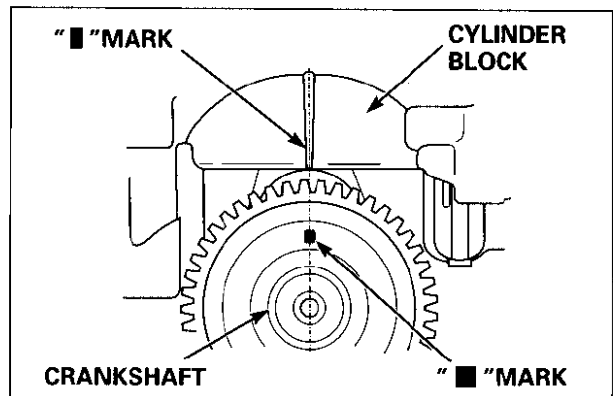

- 3) Set the timing belt on the timing belt drive pulley so that the marks on the timing belt is upside down as shown.
- 4) After installing the timing belt, install the respective cam pulley (P. 10-3).

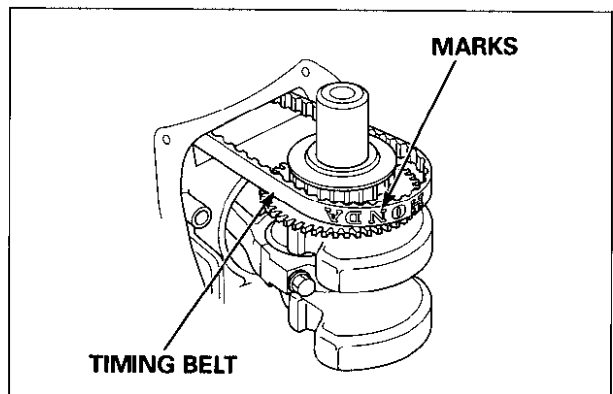

## EU2000i

- 5) Clean the mating surface of the cylinder block and the crankcase cover using a degreasing cleaning agent or a clean shop towel.
- 6) Set the 8 x 20 mm dowel pins on the cylinder block.
- 7) Apply a 1.5 – 2.0 mm (0.06 – 0.08 in) diameter bead of liquid gasket (Hondabond #4, ThreeBond #1207B or equivalent) to the cylinder block. Specifically, to the crankcase cover mating surface.
- 8) Install the crankcase cover on the cylinder block.
  - Assemble within 10 minutes after applying the liquid gasket.
  - If it is hard to install the crankcase cover securely, assemble by turning the crankshaft a little.
- 9) Hand tighten each 6 x 25 mm flange bolt, then tighten to the numbered sequence.
- 10) Wait for approximately 20 minutes after assembly before filling oil and starting the engine.

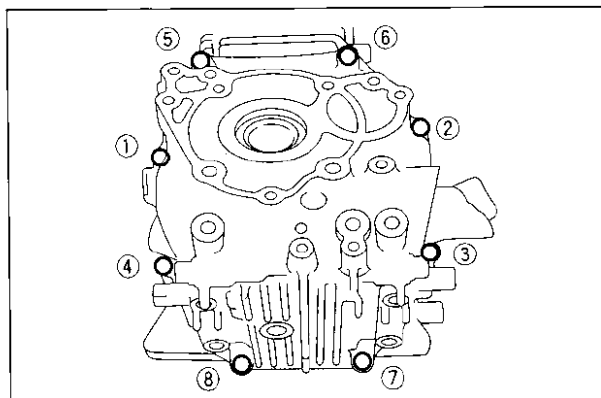
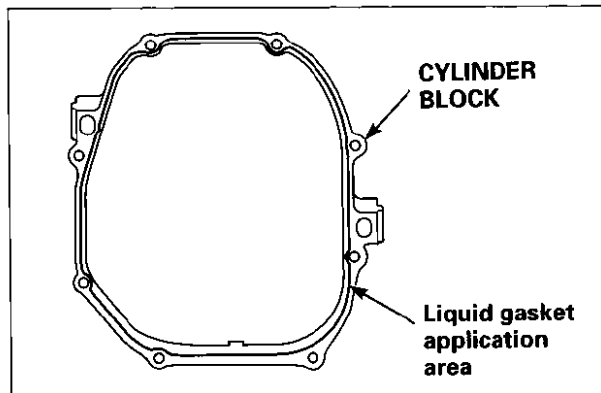



### 3. PISTON

#### a. DISASSEMBLY/REASSEMBLY

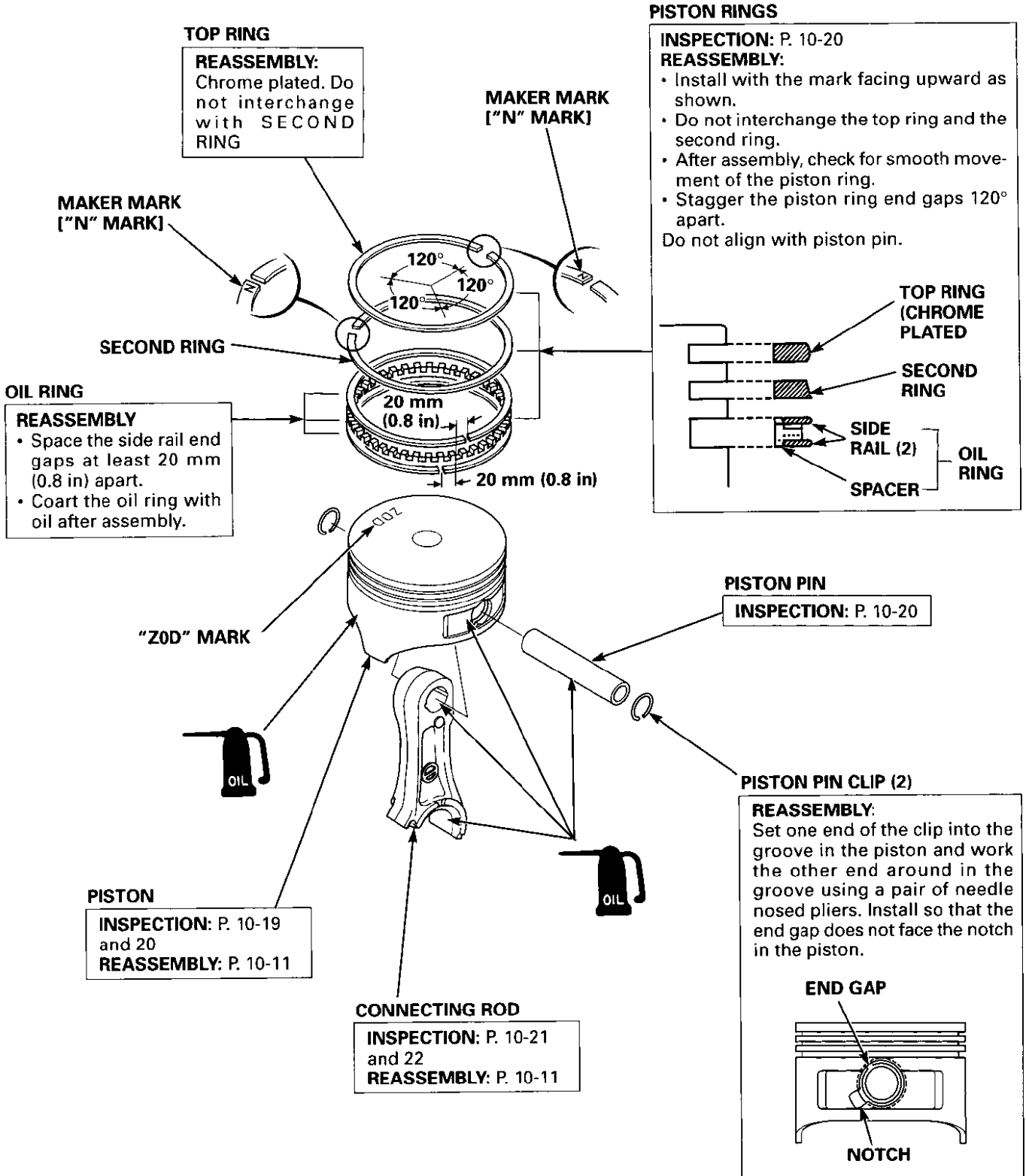

**EU2000i****• PISTON/CONNECTING ROD****REASSEMBLY:**

- 1) Apply oil to the piston pin hole and the connecting rod small hole.
- 2) Install the connecting rod in the piston so that the "ZOD" mark on the piston head points down when the connecting rod long end is facing to the right as shown.
- 3) Apply oil to the piston pin and install it in the piston.
- 4) Install new piston pin clips.
- 5) Install the piston/connecting rod assembly in the cylinder block. (P. 10-7).

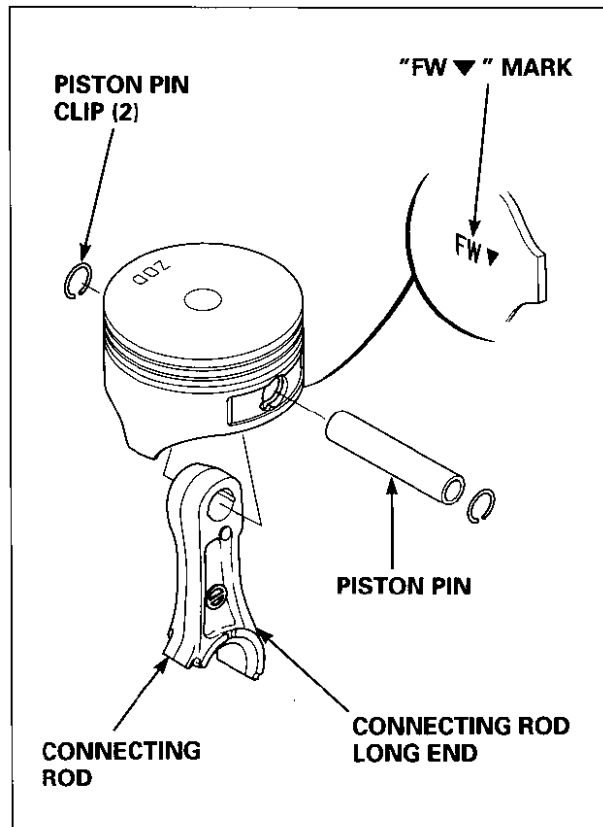

## 4. VALVES

### a. DISASSEMBLY/REASSEMBLY

Remove the crankcase cover, crankshaft and cylinder barrel (P. 10-5).

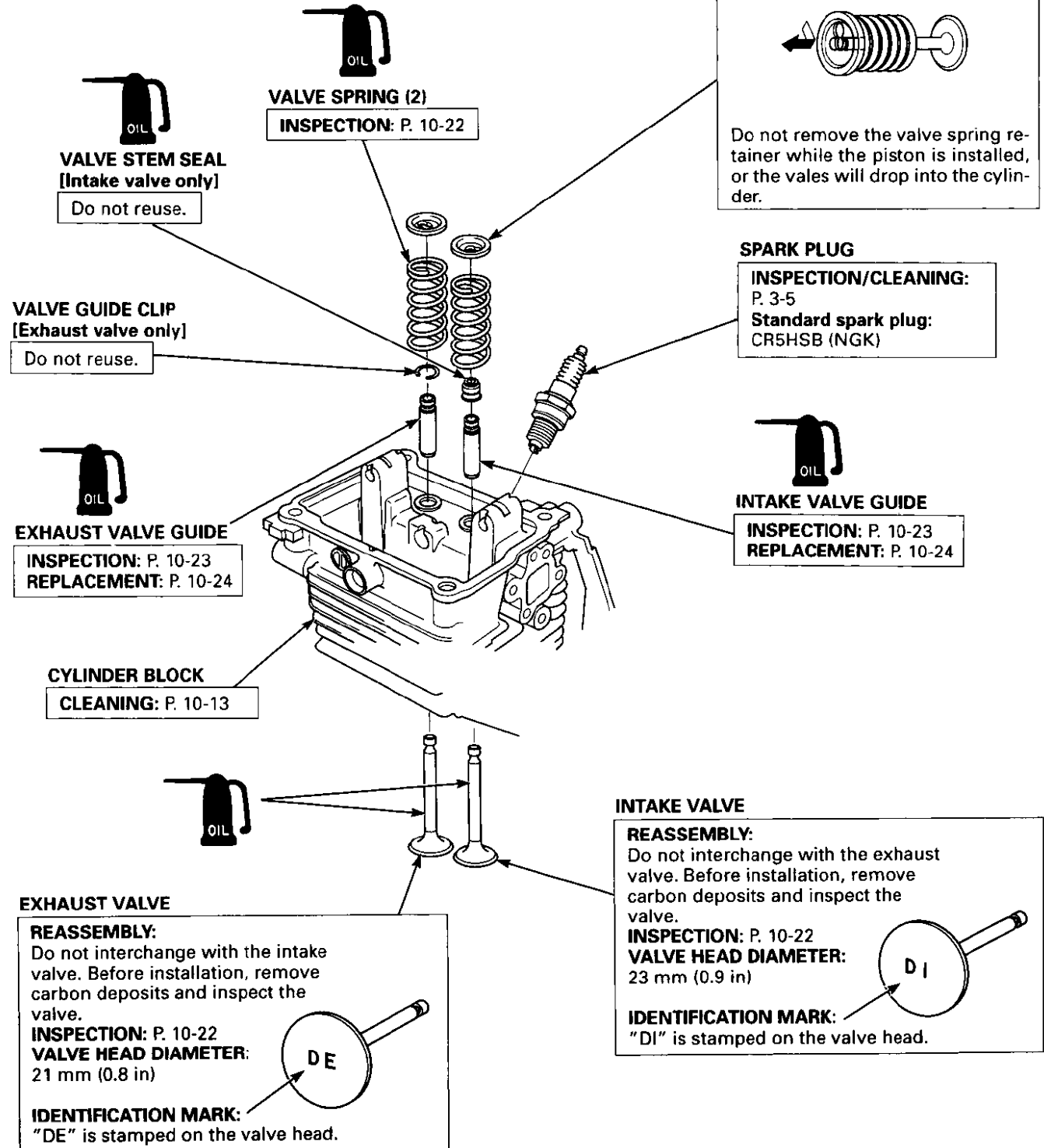

## EU2000i

### • CYLINDER BLOCK

#### COMBUSTION CHAMBER CLEANING:

- 1) Prepare a cylinder of thick paper or equivalent material, with a diameter large enough to fit against the inner wall of the cylinder, and insert it into the cylinder for protection.
- 2) Attach the cleaning brush (special tool) to an electric drill and clean the combustion chamber.

#### TOOL:

Cleaning brush

07998-VA20100

#### NOTICE

- Be sure to insert thick paper into the cylinder to protect the inner wall of the cylinder during cleaning of the combustion chamber.
- Do not press the cleaning brush with force against the combustion chamber.

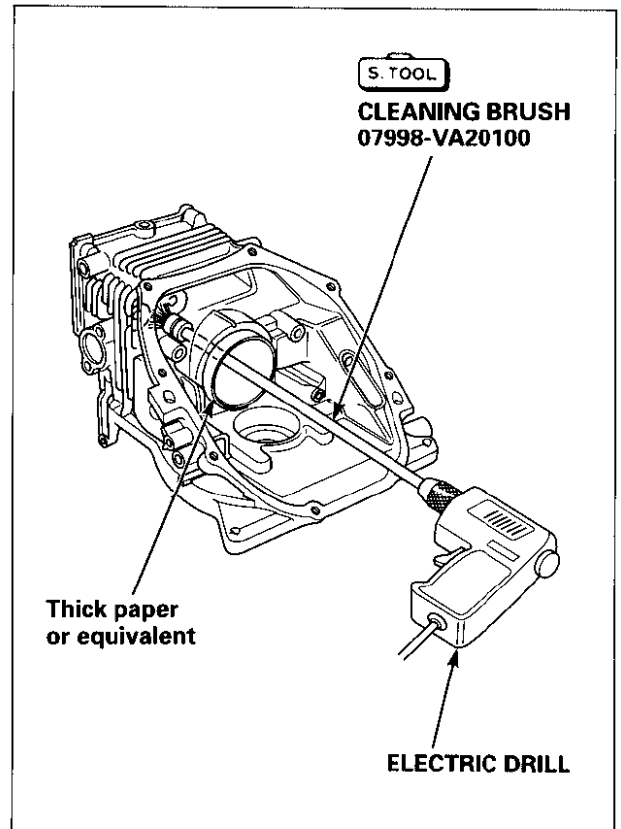

# 5. GOVERNOR

## a. DISASSEMBLY/REASSEMBLY

**SERVICE BULLETIN #33 =>**

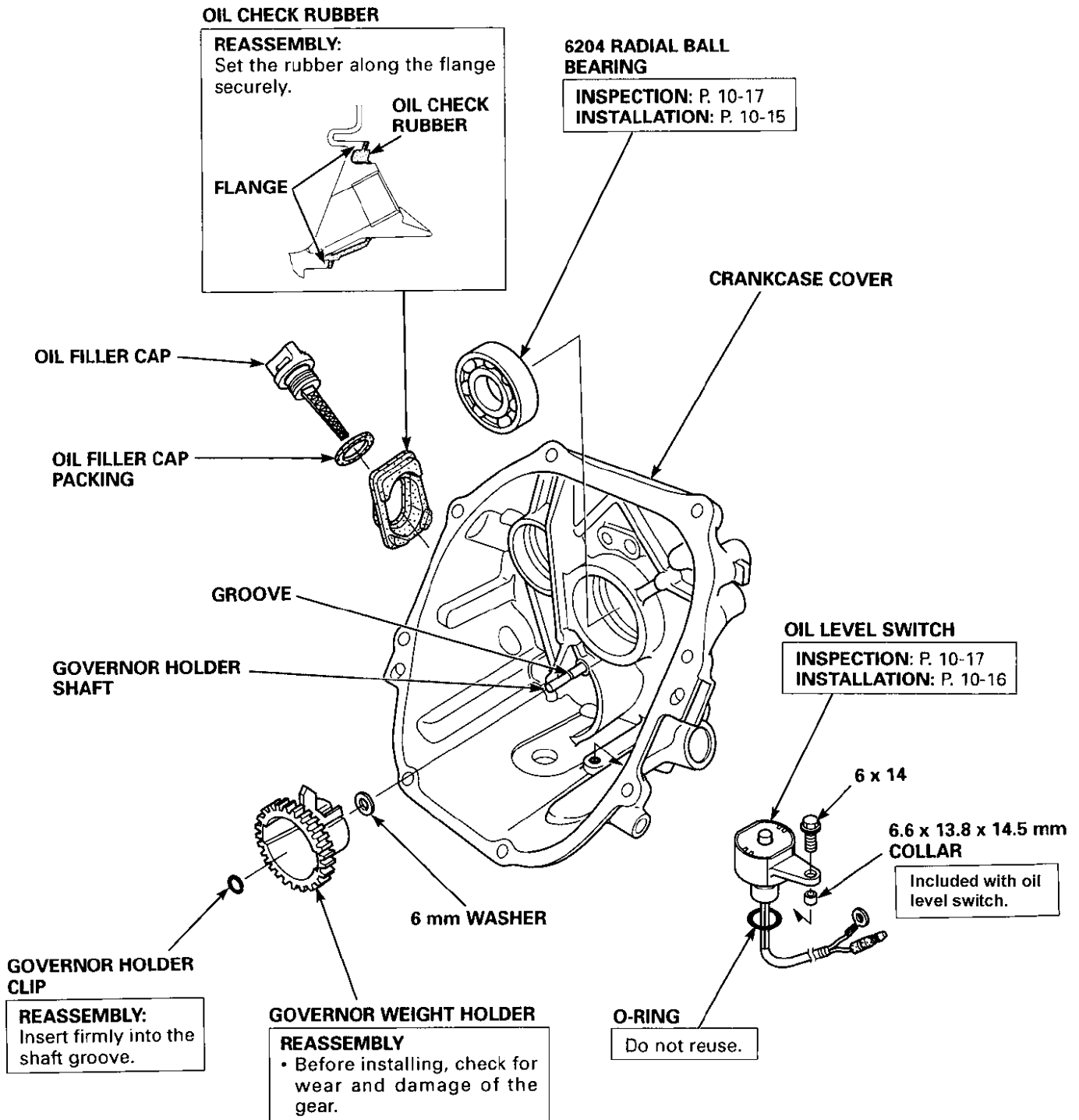

**EU2000i****• 6204 RADIAL BALL BEARING****REMOVAL:**

Remove the radial ball bearing from the crankcase cover using the special tools.

**TOOLS:**

<b>SLIDING HAMMER WEIGHT</b>	<b>07741-0010201</b>
<b>BEARING REMOVER SHAFT HANDLE</b>	<b>07936-3710100</b>
<b>BEARING REMOVER SHAFT SET 20</b>	<b>07936-3710600</b>

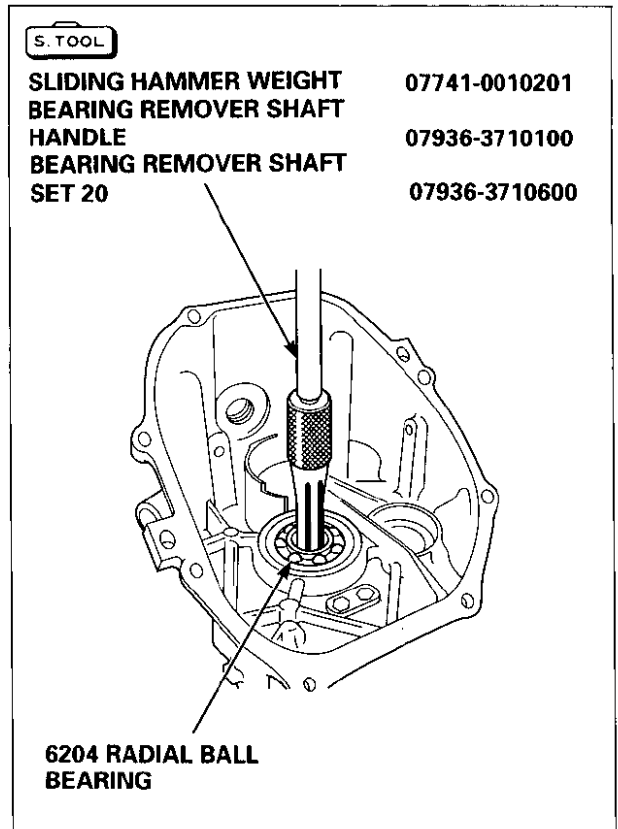
**INSTALLATION:**

- 1) Apply oil to the circumference of a new radial ball bearing.
- 2) Press the radial ball bearing in the crankcase cover using the special tools and hydraulic press.

**TOOLS:**

<b>Driver</b>	<b>07749-0010000</b>
<b>Attachment, 42 x 47 mm</b>	<b>07746-0010300</b>
<b>Pilot, 20 mm</b>	<b>07746-0040500</b>

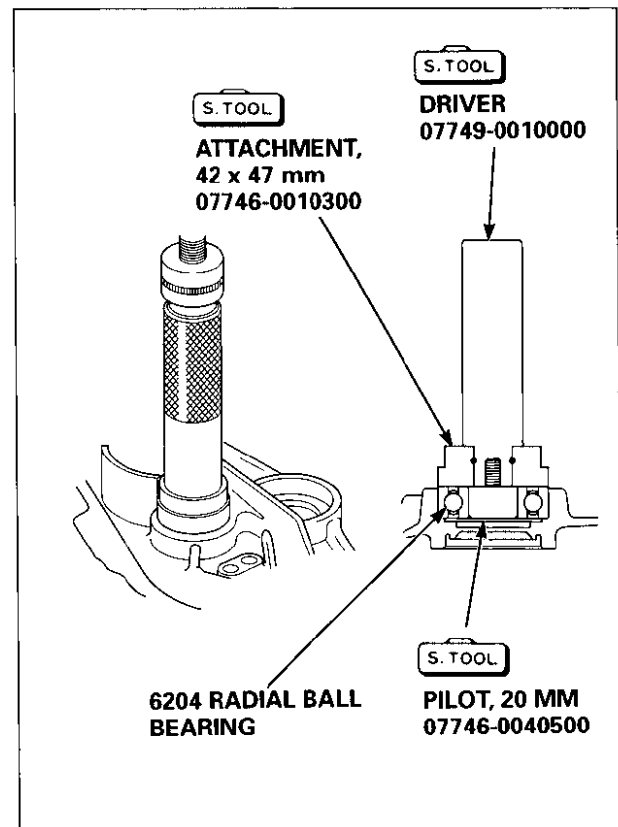

**● OIL LEVEL SWITCH****INSTALLATION:**

- 1) Install the oil level switch (P. 10-14).
- 2) Set the oil level switch wire between the ribs of the cylinder block as shown.

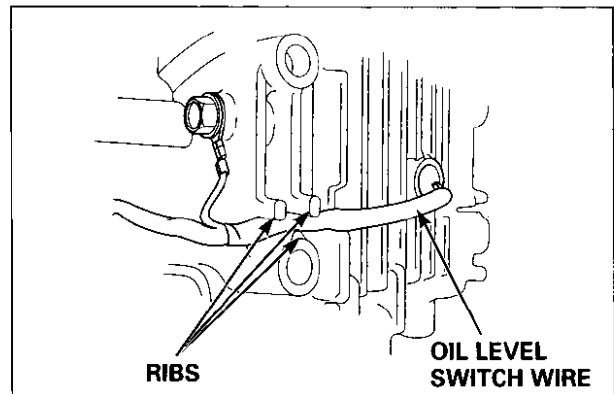

## EU2000i

### 6. INSPECTION

#### • OIL LEVEL SWITCH

Check continuity between the yellow wire and ground with an ohmmeter.

- 1) Hold the switch in its normal position. The ohmmeter should read zero resistance.
- 2) Hold the switch upside down. The ohmmeter should read infinite ( $\infty$ ) resistance.
- 3) Inspect the float by dipping the switch into a container of oil. The ohmmeter reading should go from zero to infinity as the switch is lowered.

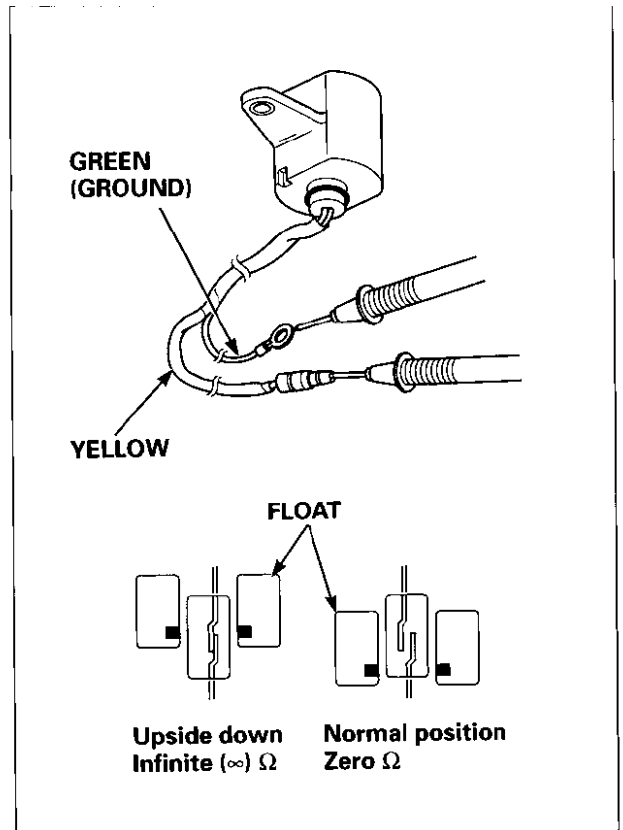

#### • 6204 RADIAL BALL BEARING

Turn the inner race of the bearing with your finger. The bearing should turn smoothly and quietly. Also check that the bearing outer race fits in place.

Replace the bearing if the inner race does not turn smoothly, quietly, or if it fits very loosely.

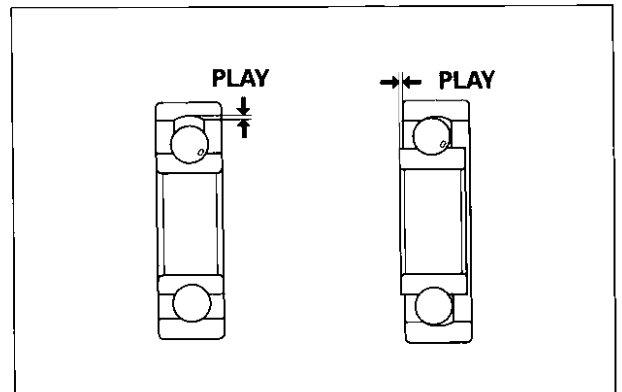

#### • CAM PULLEY

##### DECOMPRESSION WEIGHT INSPECTION:

Before installing, inspect for a worn or weakened spring, and check that the decompressor weight moves smoothly.

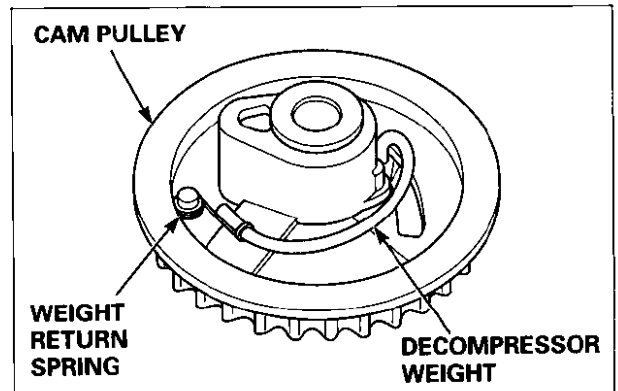



### ● CAM PULLEY CAM HEIGHT

Standard	Service limit
36.483 mm (1.4363 in)	35.483 mm (1.3970 in)

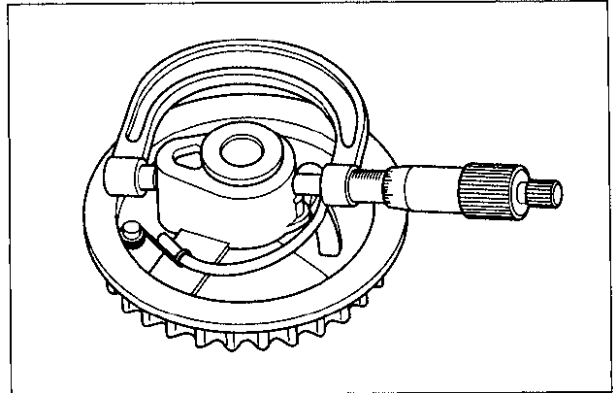

### ● CAM PULLEY I.D. (BEARING)

Standard	Service limit
10.027 – 10.057 mm (0.3948 – 0.3959 in)	10.075 mm (0.3967 in)

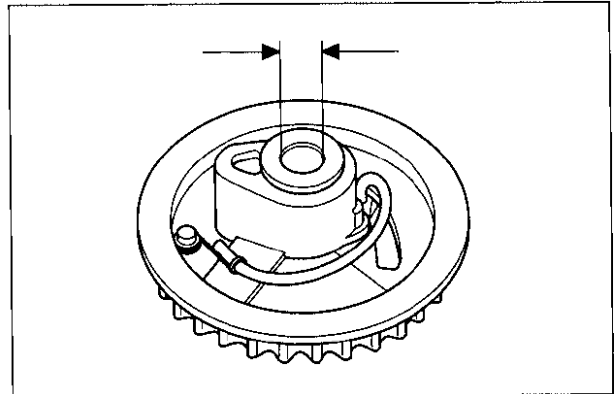

### ● CAM PULLEY SHAFT O.D.

Standard	Service limit
9.972 – 9.987 mm (0.3926 – 0.3932 in)	9.920 mm (0.3906 in)

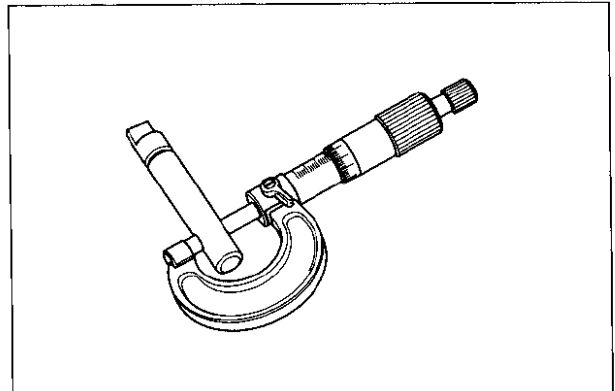

### ● ROCKER ARM I.D.

Standard	Service limit
6.000 – 6.018 mm (0.2362 – 0.2369 in)	6.043 mm (0.2379 in)

### ● ROCKER ARM SHAFT BEARING I.D.

Standard	Service limit
6.000 – 6.018 mm (0.2362 – 0.2369 in)	6.043 mm (0.2379 in)

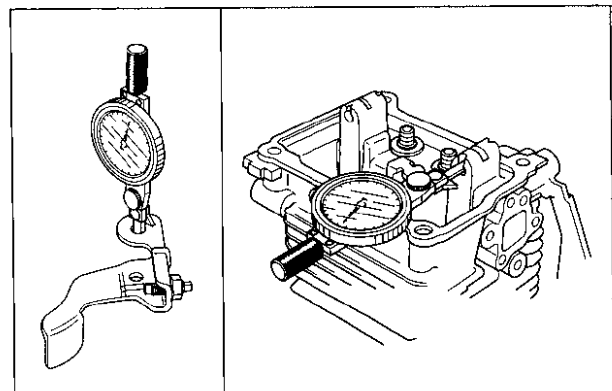

**EU2000i****• ROCKER ARM SHAFT O.D.**

Standard	Service limit
5.960 – 5.990 mm (0.2346 – 0.2358 in)	5.953 mm (0.2344 in)

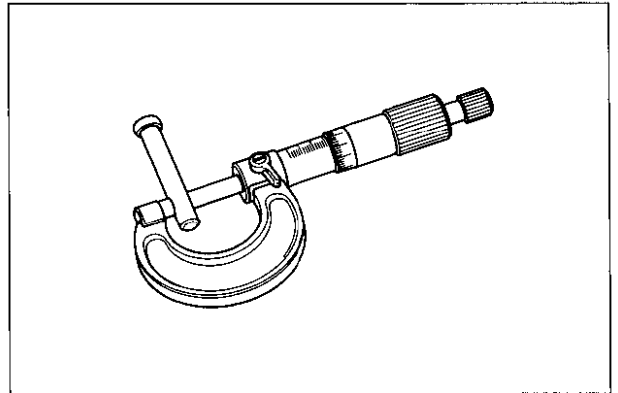
**• CYLINDER I.D.**

Measure and record the cylinder I.D. at three levels in both the "X" axis (perpendicular to crankshaft) and the "Y" axis (parallel to crankshaft). Take the maximum reading to determine cylinder wear and taper.

Standard	Service limit
56.000 – 56.015 mm (2.2047 – 2.2053 in)	56.165 mm (2.2112 in)

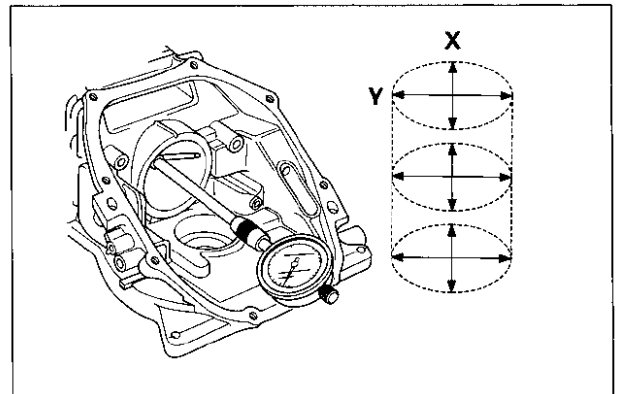
**• PISTON SKIRT O.D.**

Measure and record the piston O.D. at a point 10 mm (0.4 in) from the bottom of the skirt and 90° to the piston pin bore.

Standard	Service limit
55.965 – 55.985 mm (2.2033 – 2.2041 in)	55.85 mm (2.199 in)

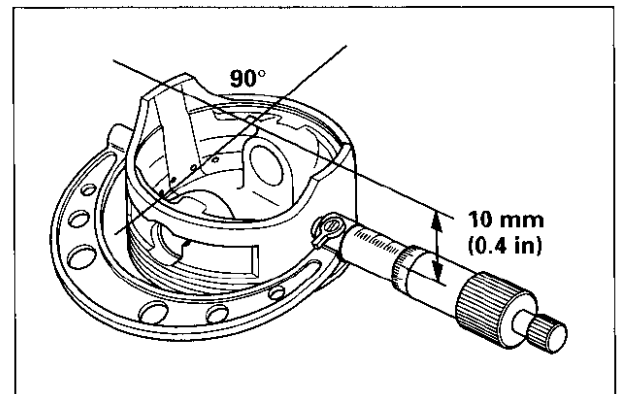
**• PISTON-TO-CYLINDER CLEARANCE**

Standard	Service limit
0.015 – 0.050 mm (0.0006 – 0.0020 in)	0.120 mm (0.0047 in)

**• PISTON PIN BORE I.D.**

Standard	Service limit
13.002 – 13.008 mm (0.5119 – 0.5121 in)	13.048 mm (0.5137 in)

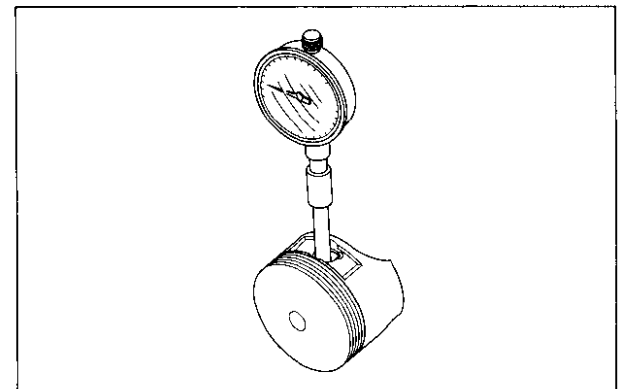

### ● PISTON PIN O.D.

Standard	Service limit
12.994 – 13.000 mm (0.5116 – 0.5118 in)	12.954 mm (0.5100 in)

### ● PISTON-TO-PISTON PIN BORE CLEARANCE

Standard	Service limit
0.002 – 0.014 mm (0.0001 – 0.0006 in)	0.080 mm (0.0031 in)

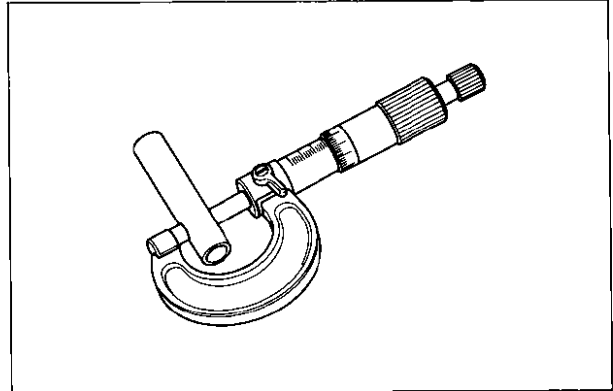

### ● PISTON RING WIDTH

	Standard	Service limit
Top	0.970 – 0.990 mm (0.0382 – 0.0390 in)	0.940 mm (0.0370 in)
second	1.170 – 1.190 mm (0.0461 – 0.0469 in)	1.140 mm (0.0449 in)

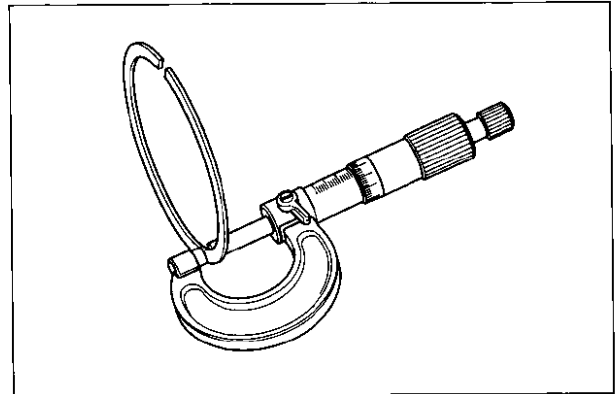

### ● PISTON RING SIDE CLEARANCE

	Standard	Service limit
Top/second	0.015 – 0.050 mm (0.0006 – 0.0020 in)	0.120 mm (0.0047 in)

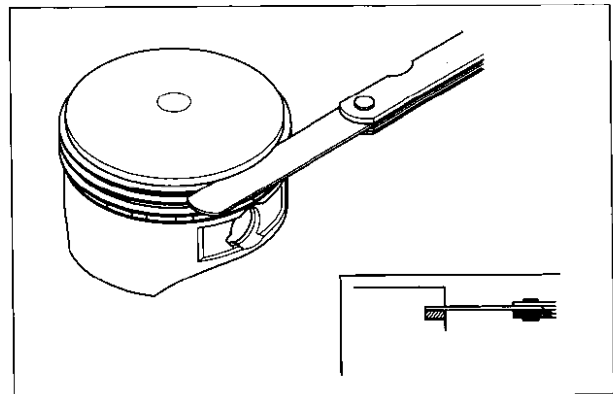

### ● PISTON RING END GAP

Before measurement, be sure to set the ring in the cylinder securely using the piston.

	Standard	Service limit
Top	0.15 – 0.30 mm (0.006 – 0.012 in)	0.60 mm (0.024 in)
second	0.30 – 0.45 mm (0.012 – 0.018 in)	0.75 mm (0.030 in)

If the measurement is too large, install a new piston ring and measure again. Then, measure the cylinder sleeve. I.D. (P. 10-19).

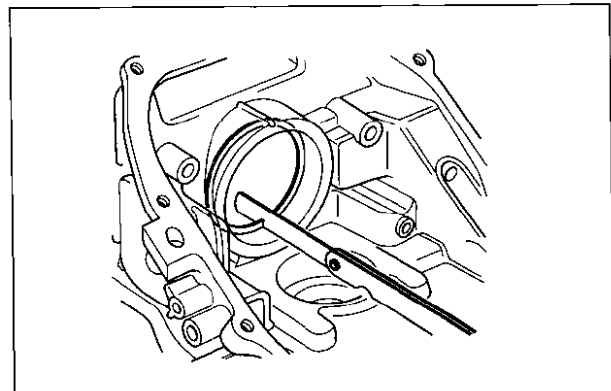

**EU2000i****• CONNECTING ROD SMALL END I.D.**

Standard	Service limit
13.005 – 13.020 mm (0.5120 – 0.5126 in)	13.070 mm (0.5146 in)

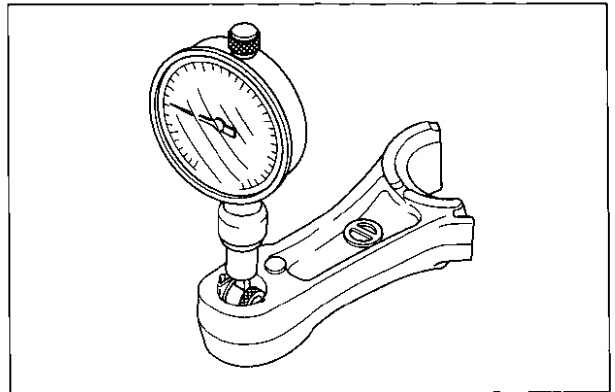
**• CONNECTING ROD BIG END I.D.**

Standard	Service limit
24.000 – 24.013 mm (0.9449 – 0.9454 in)	24.040 mm (0.9465 in)

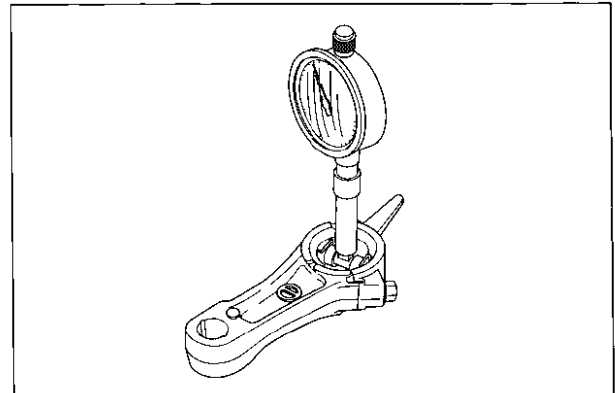
**• CRANK PIN O.D.**

Standard	Service limit
23.970 – 23.980 mm (0.9437 – 0.9441 in)	23.920 mm (0.9417 in)

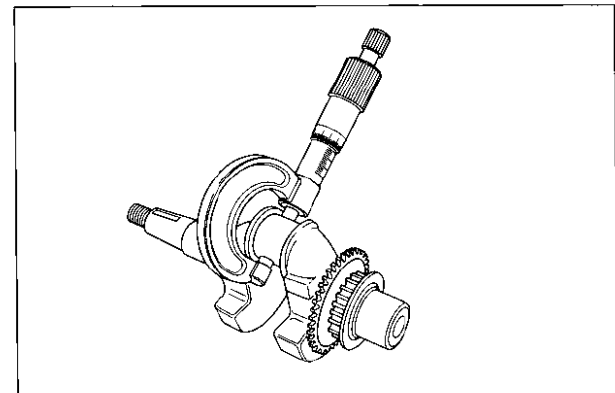
**• CONNECTING ROD BIG END AXIAL CLEARANCE**

Measure the clearance with a feeler gauge.

Standard	Service limit
0.1 – 0.4 mm (0.004 – 0.016 in)	0.800 mm (0.0315 in)

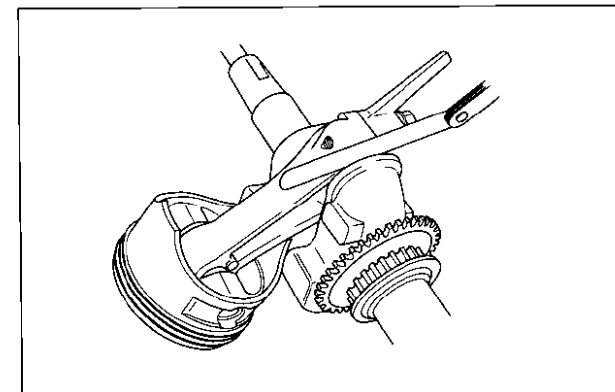

● **CONNECTING ROD BIG END OIL CLEARANCE**

- 1) Wipe oil off the crank pin and connecting rod bearing mating surface.
- 2) Place the plastigauge on the crank pin.  
Set the connecting rod and cap, and tighten the connecting rod bolts to the specified torque.  
Do not rotate or move the rod.

**TORQUE: 5 N·m (0.5 kgf·m, 3.6 lbf·ft)**

- Place the plastigauge axially.
- Tighten the two connecting rod bolts equally while holding the crankshaft to keep it from turning.

- 3) Remove the connecting rod cap and measure the plastigauge with the scale.

Standard	Service limit
0.020 – 0.043 mm (0.0008 – 0.0017 in)	0.100 mm (0.0039 in)

- 4) If the clearance exceeds the service limit, replace the connecting rod and recheck the clearance.

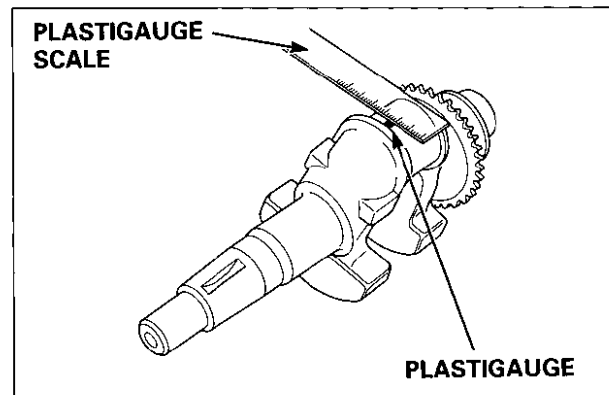
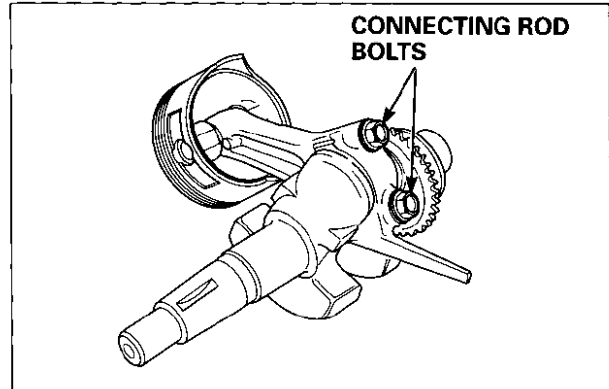

● **VALVE SPRING FREE LENGTH**

Measure the clearances with a feeler gauge.

Standard	Service limit
25.8 mm (1.02 in)	24.900 mm (0.9803 in)

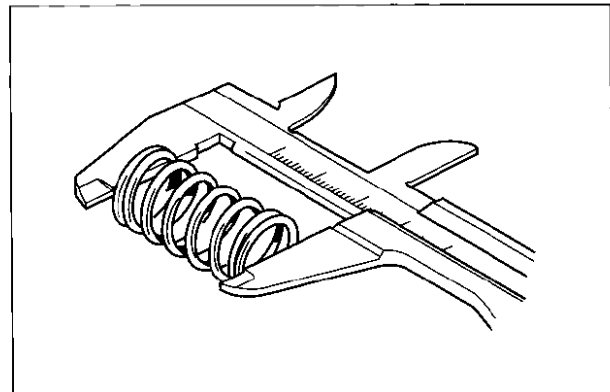

● **VALVE FACE/STEM O.D.**

Inspect each valve face for pitting or wear irregularities.  
Inspect each valve stem for bending or abnormal stem wear.  
Replace the valve if necessary.

Measure and record each valve stem O.D..

	Standard	Service limit
IN	3.970 – 3.985 mm (0.1563 – 0.1569 in)	3.900 mm (0.1535 in)
EX	3.935 – 3.950 mm (0.1549 – 0.1555 in)	3.880 mm (0.1528 in)

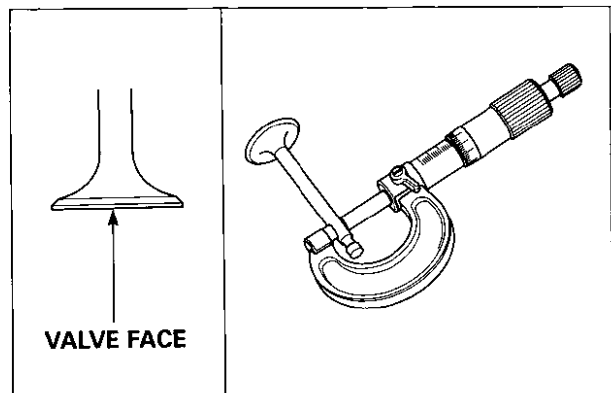

Replace the valve if their O.D. is smaller than the service limit.

## EU2000i

### • VALVE GUIDE I.D.

Using the valve guide reamer (special tool), ream the valve guides to remove any carbon deposits before measuring.

Measure and record each valve guide I.D..

	Standard	Service limit
IN/EX	4.000 – 4.018 mm (0.1575 – 0.1582 in)	4.060 mm (0.1598 in)

Replace the valve guides if they are over the service limit (P. 10-24).

### • VALVE STEM-TO-VALVE GUIDE CLEARANCE

Subtract each valve stem O.D. from the corresponding guide I.D. to find the clearance.

	Standard	Service limit
IN	0.015 – 0.048 mm (0.0006 – 0.0019 in)	0.098 mm (0.0039 in)
EX	0.050 – 0.083 mm (0.0020 – 0.0033 in)	0.120 mm (0.0047 in)

If the stem-to-guide clearance exceeds the service limit, determine if the new guide with standard dimensions would bring the clearance within tolerance. If so, replace any guide as necessary and ream to fit. If the stem-to-guide clearance exceeds the service limit with new guides, replace the valves as well.

Recondition the valve seats whenever the valve guides are replaced (P. 10-26).

### • VALVE SEAT WIDTH

Measure the valve seat width. Apply Prussian Blue compound or erasable felt-tipped marker to the valve faces. Insert the valves, and then lift them and snap them closed against their seats several times. Be sure the valve does not rotate on the seat. The seating surface, as shown by the transferred marking compound, should have good contact all the way around.

	Standard	Service limit
IN/EX	0.7 mm (0.028 in)	1.800 mm (0.0709 in)

If the valve seat width is under the standard, or over the service limit, or if the valve seat is too high/low, recondition the valve seat (P. 10-26).

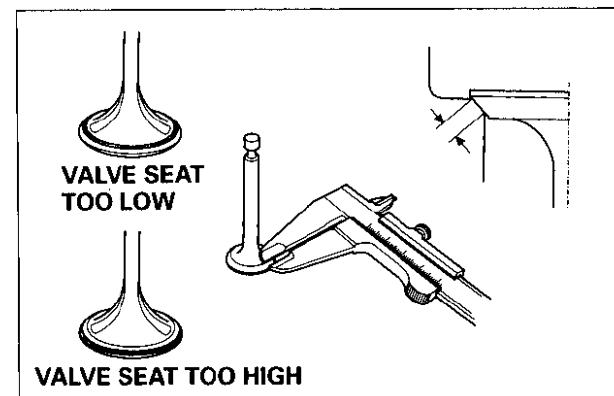
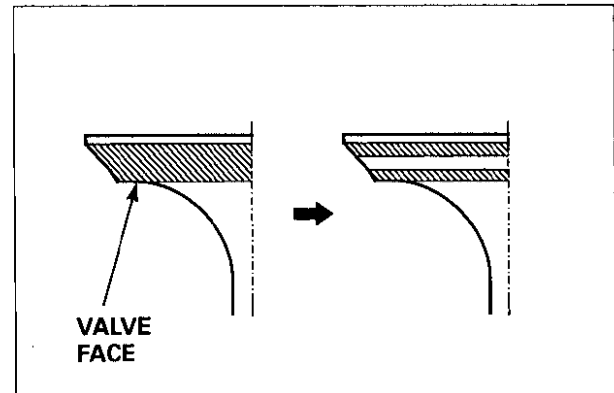
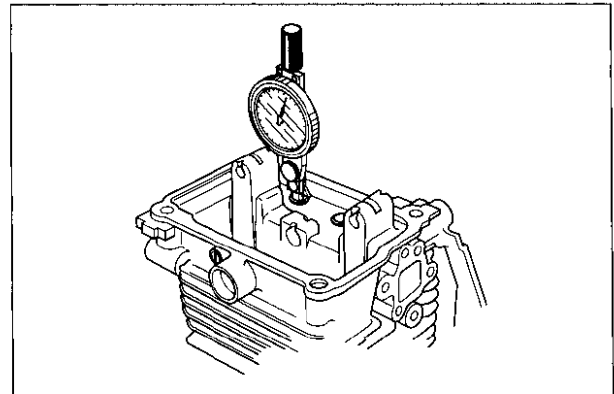
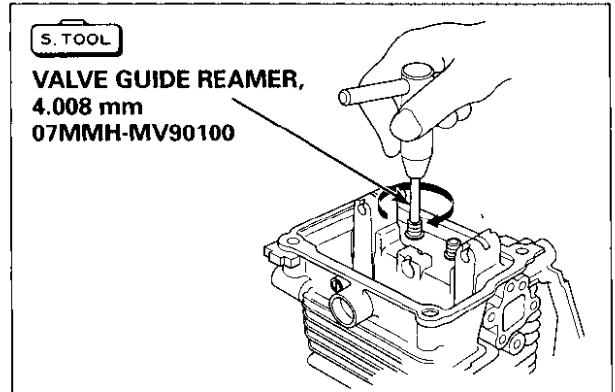

## 7. VALVE GUIDE REPLACEMENT

- 1) Chill the replacement valve guides in the freezer section of a refrigerator for about an hour.
- 2) Use a hot plate or oven to heat the cylinder block evenly to 150 °C (300 °F). Check the temperature with a temperature indicating stick (available at welding supply store) or equivalent.

### NOTICE

- Do not use a torch to heat the cylinder block; warpage of the cylinder block may result.
- Do not get the heat hotter than 150 °C (300 °F); excessive heat may loosen the valve seats.

- 3) Remove the heated cylinder block from hot plate, and support it with wooden blocks. Wear heavy gloves to protect your hands.
- 4) Drive the valve guides out the cylinder block from the combustion chamber side.

### TOOL:

Valve guide driver, 3.6 x 8.0 mm                      07JMD-KY20100

### NOTICE

Be careful to avoid damaging the cylinder block when driving out the valve guides.

- 5) Allow the cylinder block to cool to room temperature. Clean and inspect the valve guide bores in the cylinder block. Wash out any foreign material.
- 6) Use a hot plate or oven to heat the cylinder block evenly to 150 °C (300 °F). Check the temperature with a temperature indicating stick or equivalent.
- 7) Install the new valve guides from the valve spring side of the cylinder block.

### TOOL:

Valve guide driver, 3.6 x 8.0 mm                      07JMD-KY20100

Exhaust side: Drive the exhaust valve guide until the clip is fully seated as shown.

Intake side: Drive the intake valve guide to the specified height, measured from the top of the valve guide to the cylinder block casting as shown.

Valve guide extrusion amount	IN	6.0 mm (0.24 in)
------------------------------	----	------------------

- 8) After installation, inspect the valve guides for damage. Replace any damaged valve guide.

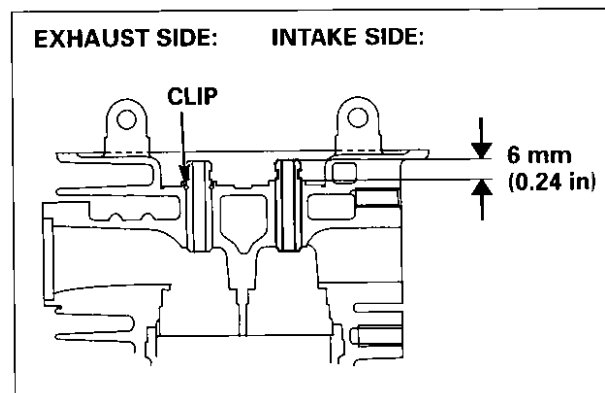
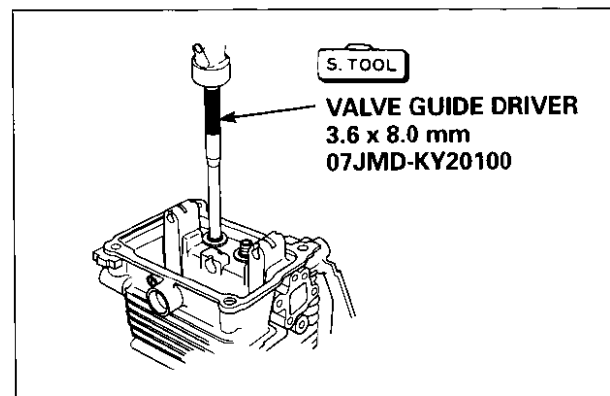
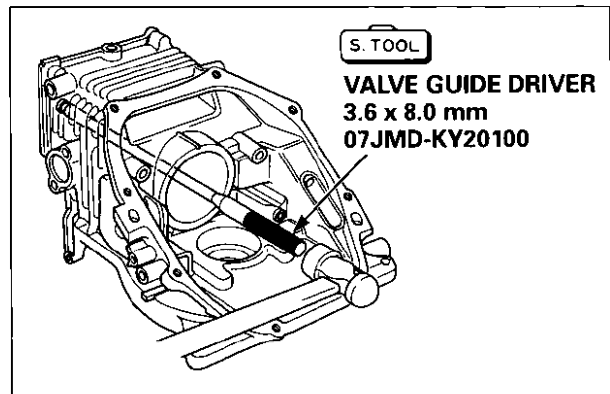

## EU2000i

### • VALVE GUIDE REAMING

For best results, be sure the cylinder block is at room temperature before reaming valve guides.

- 1) Coat the reamer and valve guide with cutting oil.
- 2) Rotate the reamer clockwise through the valve guide for the full length of the reamer.
- 3) Continue to rotate the reamer clockwise while removing it from the valve guide.

#### TOOL:

**Valve guide reamer, 4.008 mm      07MMH-MV90100**

- 4) Thoroughly clean the cylinder block to remove any cutting residue.
- 5) Check the valve guide bore; it should be straight, round and centered in the valve guide, insert the valve and check operation. If the valve does not operate smoothly, the guide may have been bent during installation. Replace the valve guide if it is bent or damaged.
- 6) Check the valve guide-to-stem clearance (P. 10-23).

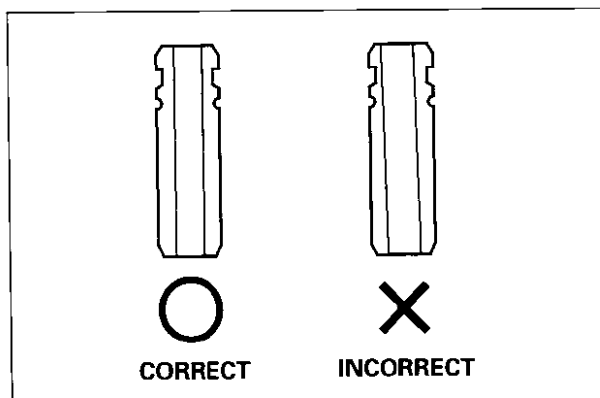
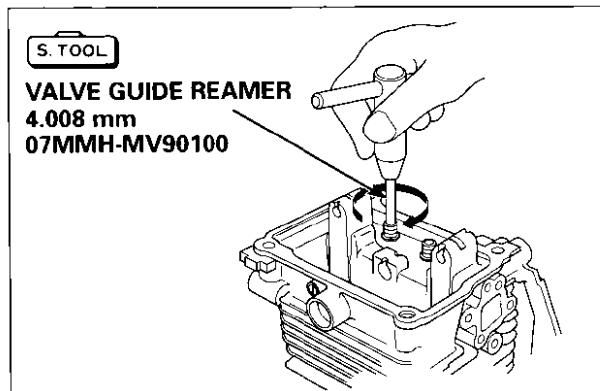



## 8. VALVE SEAT RECONDITIONING

- 1) Thoroughly clean the combustion chamber and valve seats to remove carbon deposits (P. 10-13).
- 2) Apply a light coat of Prussian Blue compound or erasable felt-tipped marker ink to the valve faces.
- 3) Insert the valves, and then lift them and snap them closed against their seats several times. Be sure the valve does not rotate on the seat. The transferred marking compound will show any area of the seat that is not concentric.

### NOTICE

Follow the valve seat cutter manufacturer's Instructions.

- 4) Using a 45° cutter, remove enough material to produce a smooth and concentric seat. Turn the cutter clockwise, never counterclockwise. Continue to turn the cutter as you lift it from the valve seat.

### TOOLS:

(Special tools or equivalent commercially available)

Valve seat cutter, 45° 24.5 mm (IN)	07780-0010100
Valve seat cutter, 45° 24 mm (EX)	07780-0010600
Valve seat cutter, 32° 25 mm (IN)	07780-0012000
Valve seat cutter, 32° 24 mm (EX)	07780-0012500
Valve seat cutter, 60° 24 mm (IN/EX)	070PH-Z0D0100
Cutter holder, 4.0 x 400 mm	070PH-Z0D0200

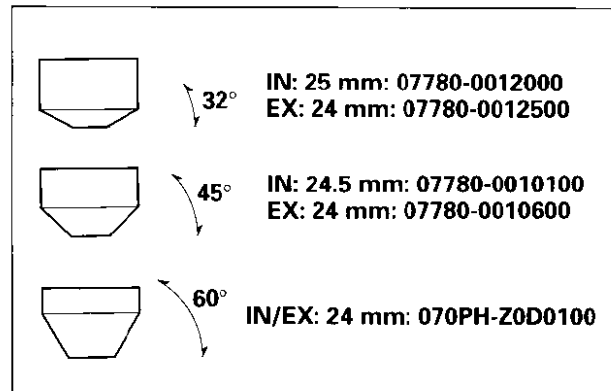
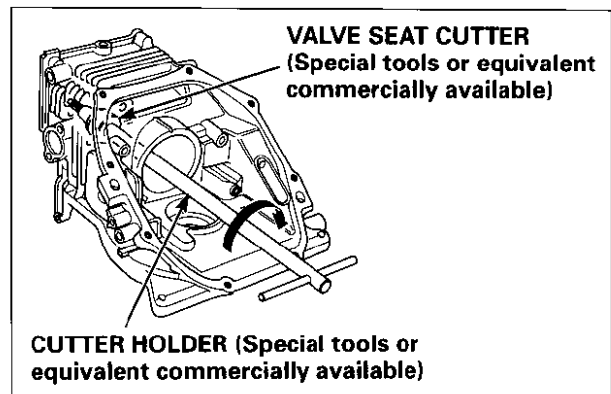
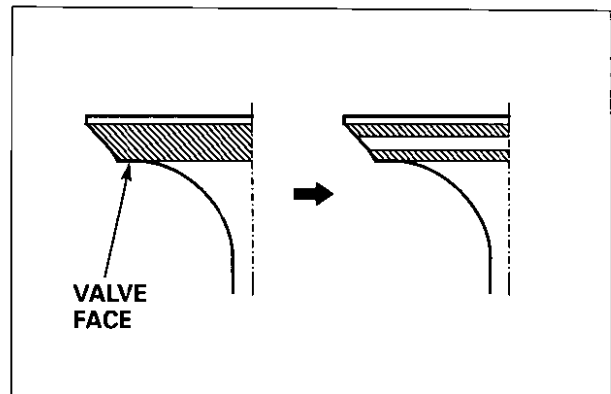

- 5) Use the 32° and 60° cutters to narrow and adjust the valve seat so that it contacts the middle of the valve face. The 32° cutter removes material from the top edge. The 60° cutter removes material from the bottom edge. Be sure that the width of the finished valve seat is within specification (P. 10-27).

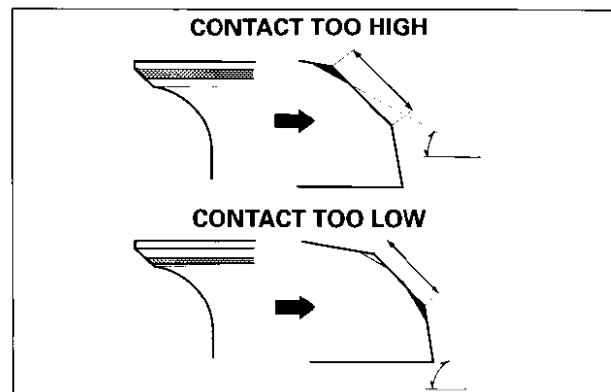

**EU2000i**

	Standard	Service limit
IN/EX	0.7 mm (0.028 in)	1.800 mm (0.0709 in)

- 6) Make a light pass with 45° cutter to remove any possible burrs at the edges of the seat.
- 7) After resurfacing the seat, inspect for even valve seating. Apply Prussian Blue compound or erasable felt-tipped marker ink to the valve faces. Insert the valves, and then lift them and snap them closed against their seats several times. Be sure the valve does not rotate on the seat. The seating surface, as shown by the transferred marking compound, should have good contact all the way around.
- 8) Lap the valves into their seats, using a 4 mm tube as shown and lapping compound (commercially available).

**NOTICE**

*To avoid severe engine damage, be sure to remove all lapping compound from the combustion chamber before assembly.*

- 9) Check valve clearance after assembly (P. 3-5).

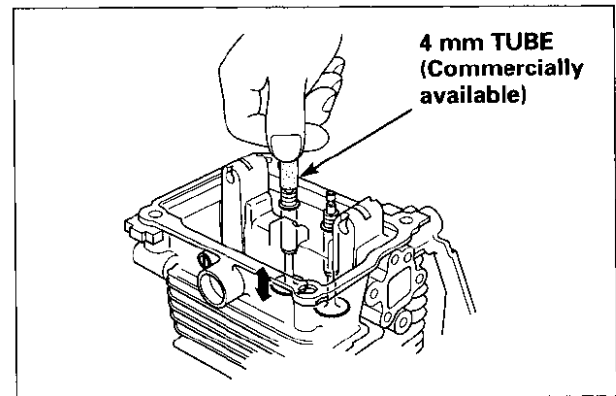
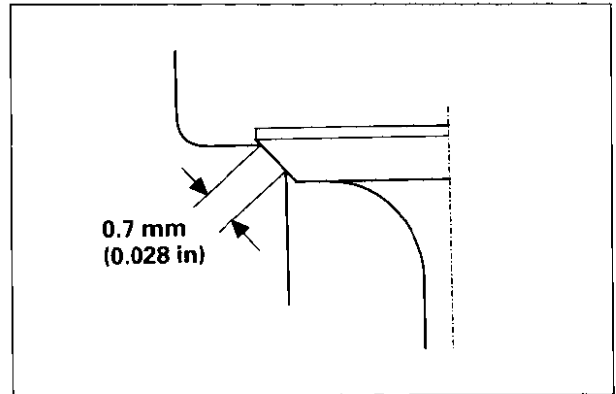



# 11. OPERATION

## EU2000i

1. INVERTER TYPE GENERATOR..... 11-1	3. ECO-THROTTLE (ELECTRICAL GOVERNOR) .....11-3
2. FULL TRANSISTOR IGNITION ..... 11-2	

## 1. INVERTER TYPE GENERATOR

### CONSTRUCTION

The Inverter generator has an outer and an inner rotating set of magnets for both the generator and the ignition. The inner set of magnets generate AC in the stator windings, while the outer set generates AC for the ignition coil. A multi-pole coil is used on the stator (15 poles for the AC winding, 6 poles for the DC winding, 1 pole for the sub winding, and 1 pole for the exciter winding). The AC coil in the stator is picked up by the inverter.

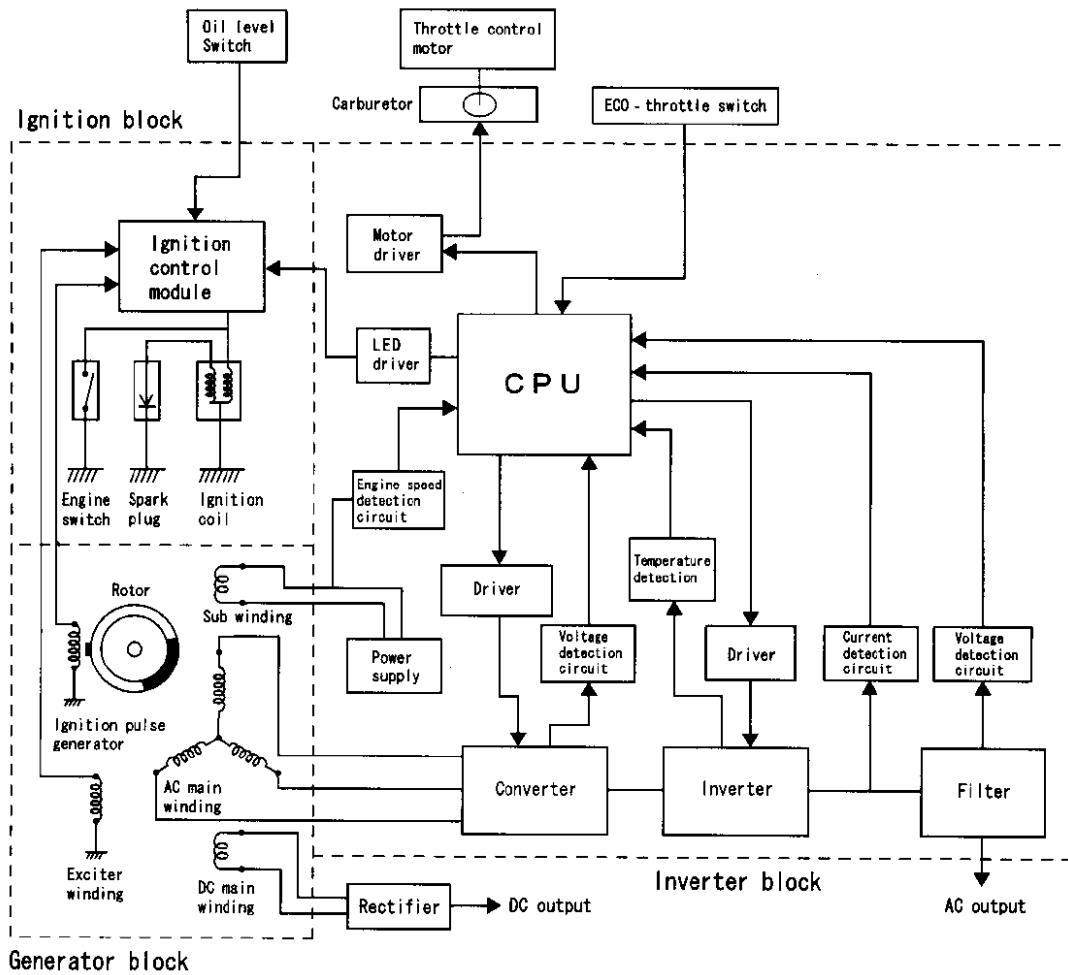

### Operating Principles

When the rotor rotates, the AC (3-phase) is generated at the AC main winding, which is converted into DC by the regulator/rectifier. The voltage is stabilized by the regulator/rectifier in the converter simultaneously. The AC generated at the sub winding becomes the power source for each circuit and elemental device, such as an inverter built-in power transistor. Getting a signal from the oscillator circuit, the inverter that controls the LED generates the AC (single phase) of the proper frequency.

#### • AC Overload Protection System

The power output indicator light (green LED) is on while the generator is running with normal load. When overloaded, the overload warning light turns on by getting signal from the output current detecting circuit to indicate overloading. When the generator runs overloaded for more than 5 seconds, the circuit cuts off the AC to protect the generator. When the output is cut off due to overloading, stop the engine and disconnect the attached electrical device from the generator to remove the load. Start the engine again. The LED (green) should turn on.

## 2. FULL TRANSISTOR IGNITION

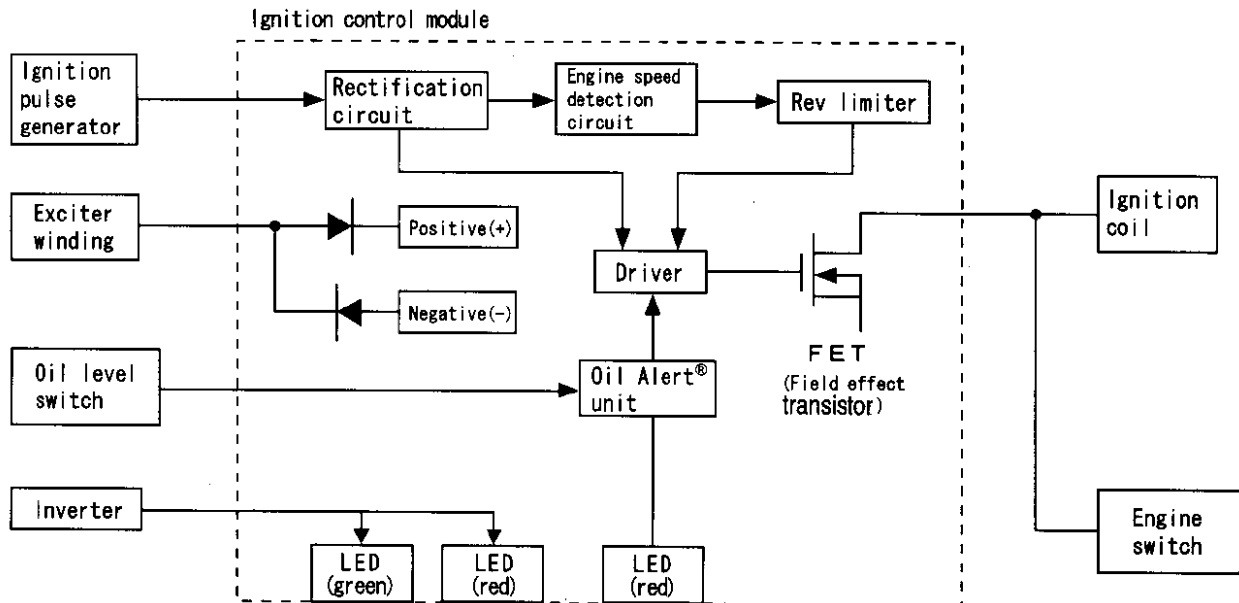

### Operating Principles

The positive (+) and negative (-) power sources are provided from the exciter winding. AC current is provided to the Ignition coil from the negative (-) power source. Current switching to the ignition coil is controlled by the Field Effect Transistor (FET).

The FET turns on when the pulse pole front end reaches the ignition pulse generator and starts to amplify the current in the ignition coil primary winding. The FET turns off when the pulse pole back end has passed the ignition pulse generator, which stops the current in the ignition coil primary winding. The high voltage is then generated in the ignition coil secondary winding (ignition point).

#### • Rev Limiter

The engine is equipped with a rev limiter to protect the generating system from excessive engine speed. The rev limiter receives its signal from the ignition pulse generator. If the engine speed reaches a predetermined level, the rev limiter will be activated and will cut off the ignition system.

#### • Oil Alert® System

The Oil Alert® unit will cut off the ignition system when the engine oil falls to a predetermined level by turning on the oil level switch and the red light emitting diode (LED), which acts as a warning light. The red LED will remain lit approximately two seconds after engine stops using electrical energy from the condenser in the ignition control module.

#### • Electrical Source

The engine is operated by the dual electrical source: the positive (+) half-wave and the negative (-) half-wave. The diodes convert AC that is generated at the exciter winding to the positive (+) half-wave and the negative (-) half-wave AC currents. The positive (+) half-wave becomes the power source for the rev limiter while the negative (-) half-wave becomes the power source for the ignition system and the Oil Alert® unit. Both of the half waves become the power source for the FET gate drive. This system realizes a stable rev limiter activating condition and a Field Effect Transistor (FET) ignition system.

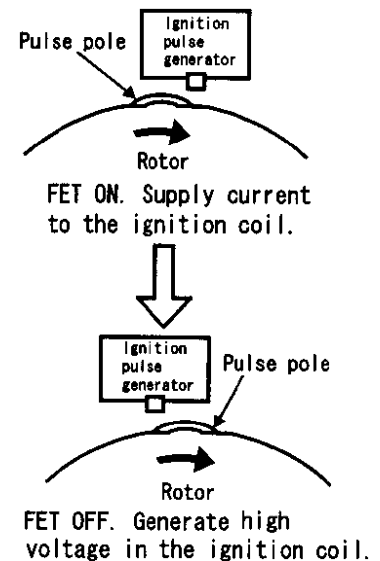

**EU2000i**

**3. ECO-THROTTLE (ELECTRICAL GOVERNOR)**

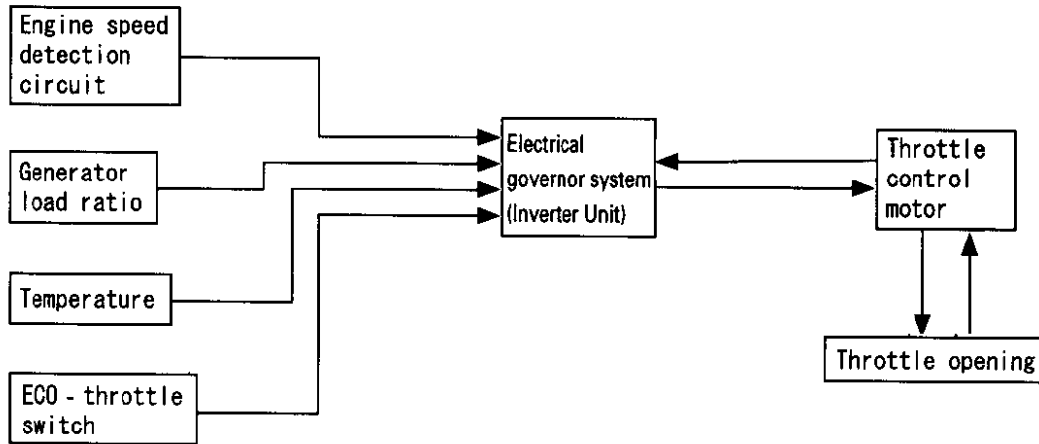

**Operating Principles**

• **Variable Engine Speed**

The inverter's CPU compares the current output voltage, current and engine speed with what is programmed in its memory and sets the throttle position accordingly. The actual required engine speed then is based on generator load ratio and temperature. As a load is applied, the engine speed, generator output power will drop momentarily. The inverter will calculate the type of load (how much of power drop is occurring) and set the engine speed accordingly.

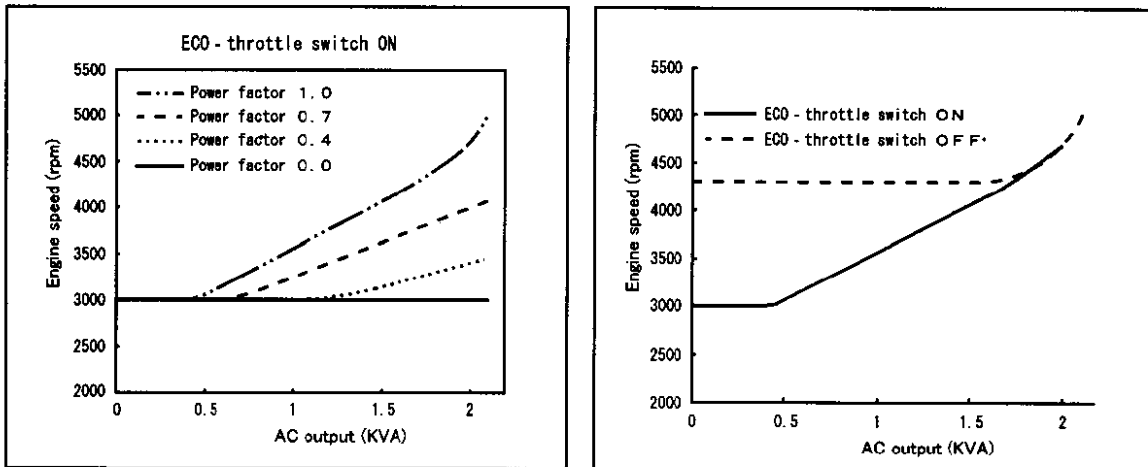

• **Engine Stall Prevention System**

Detecting the engine load by the throttle opening the system prevents engine speed from going down when the load is excessively high, beyond engine load capacity by controlling the output voltage at the inverter. This system is able to generate maximum power more efficiently, and control peak performance for applications that require more electric power, such as motors. The system automatically activates higher engine speeds in order to compensate for the power loss of the engine when used in the high altitude or deterioration if the generator caused over time.



**HONDA**  
**Power**  
**Equipment**

# SHOP MANUAL

## EU2000i Companion

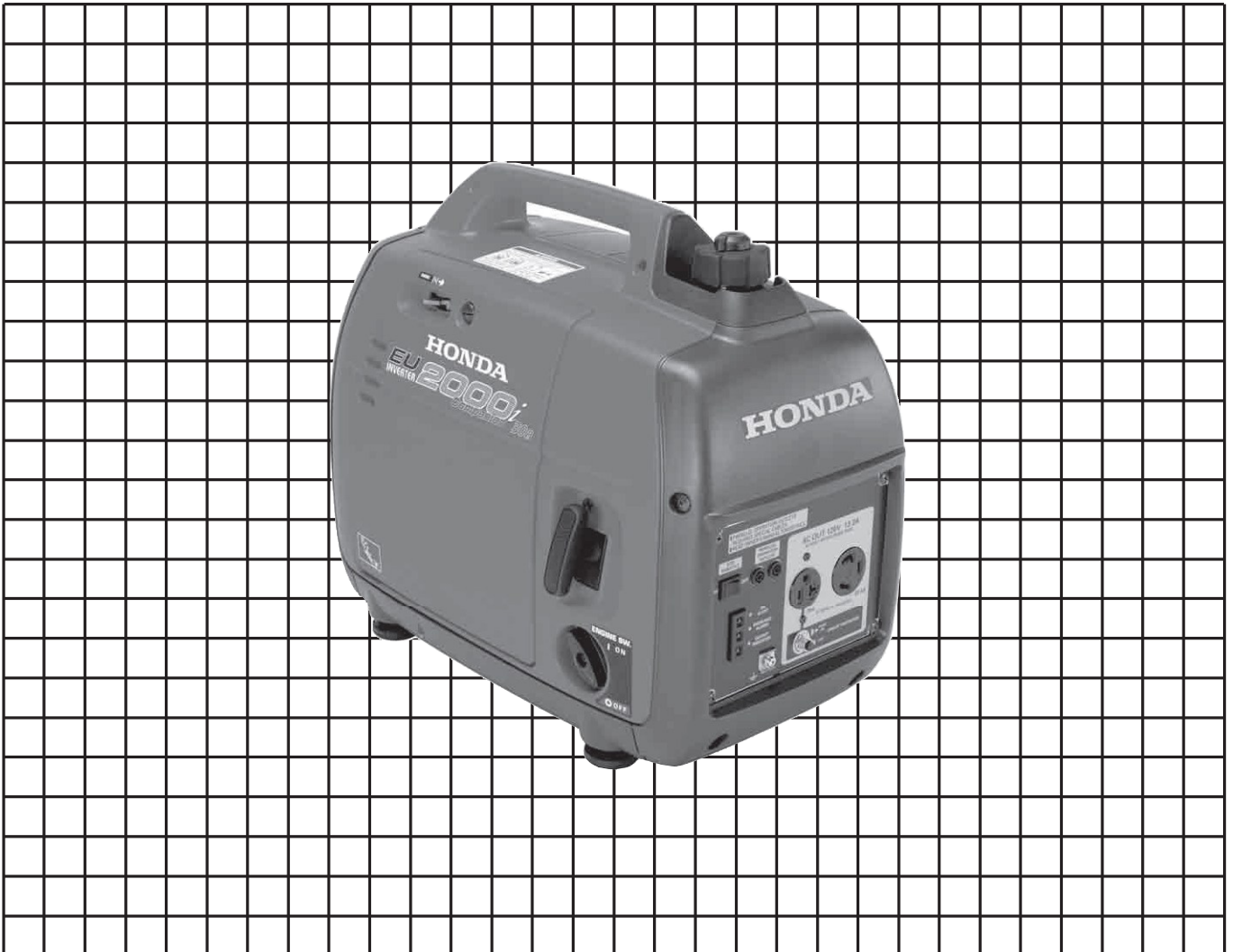





## EU2000i COMPANION

### INTRODUCTION

This supplement covers service and repair procedures for Honda EU2000i Companion (AC1 (California), AN1 (Non-California) types) generators.

All information contained in this manual is based on the latest product information available at the time of printing. We reserve the right to make changes at any time without notice.

No part of this publication may be reproduced, stored in a retrieval system, or transmitted, in any form by any means, electronic, mechanical, photocopying, recording, or otherwise, without prior written permission of the publisher. This includes text, figures, and tables.

As you read this manual, you will find information that is preceded by a **NOTICE** symbol. The purpose of this message is to help prevent damage to the generator, other property, or the environment.

#### SAFETY MESSAGES

Your safety and the safety of others are very important. To help you make informed decisions, we have provided safety messages and other safety information throughout this manual. Of course, it is not practical or possible to warn you about all the hazards associated with servicing these generators. You must use your own good judgement.

You will find important safety information in a variety of forms, including:

- **Safety Labels** – on the generator.
- **Safety Messages** – preceded by a safety alert symbol  and one of three signal words: DANGER, WARNING, or CAUTION.

These signal words mean:

#### DANGER

You **WILL** be KILLED or SERIOUSLY HURT if you don't follow instructions.

#### WARNING

You **CAN** be KILLED or SERIOUSLY HURT if you don't follow instructions.

#### CAUTION

You **CAN** be HURT if you don't follow instructions.

- **Instructions** – how to service these generators correctly and safely.

American Honda Motor Co., Inc.  
Service Communications Department

### CONTENTS

OUTLINE OF CHANGES	
SPECIFICATIONS	1
SERVICE INFORMATION	2
MAINTENANCE	3
MUFFLER	4
AIR CLEANER/CARBURETOR	5
CONTROL PANEL	6
SIDE COVERS/FUEL TANK/ FRONT FRAMES/UNDER COVER	7
RECOIL STARTER/FAN COVER	8
GENERATOR	9
CAM PULLEY/CRANKSHAFT/ PISTON/CYLINDER BLOCK	10
OPERATION	11

The marked sections contain no changes. They are not covered in this supplement.

**EU2000i COMPANION**

---

---

# EU2000i COMPANION

# OUTLINE OF CHANGES

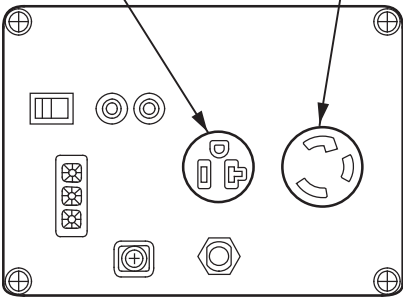
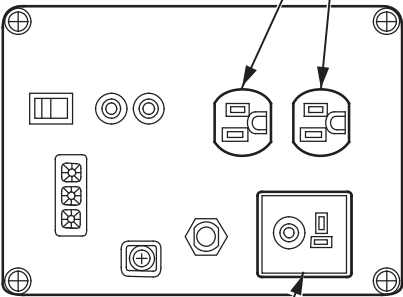
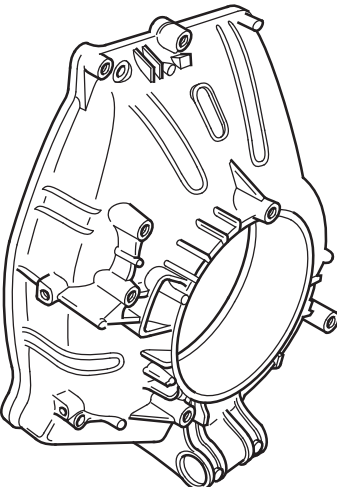
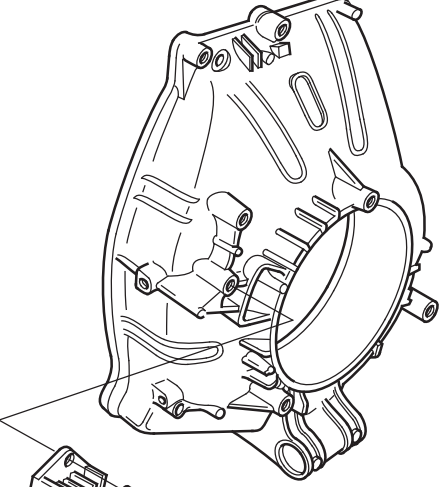
	EU2000i Companion	EU2000i
Control panel	<p>AC RECEPTACLE (125V - 20A)</p> <p>AC RECEPTACLE (125V - 30A)</p> 	<p>AC RECEPTACLE (125V - 20A)</p> <p>DC RECEPTACLE</p> 
Rectifier (Eliminated)		 <p>RECTIFIER</p>

# **EU2000i COMPANION**

---

---

**EU2000i COMPANION****1. SPECIFICATIONS**

<b>1. SPECIFICATIONS.....</b>	<b>1-1</b>	<b>3. DIMENSIONAL DRAWINGS.....</b>	<b>1-4</b>
<b>2. CHARACTERISTICS .....</b>	<b>1-2</b>	<b>4. WIRING DIAGRAM .....</b>	<b>1-5</b>

**1. SPECIFICATIONS****DIMENSIONS AND WEIGHTS**

Model	EU2000i COMPANION
Type	AC1 *1, AN1 *2
Overall length	512 mm (20.2 in)
Overall width	290 mm (11.4 in)
Overall height	425 mm (16.7 in)
Dry weight	20.8 kg (45.9 lb)
Operating weight	23.9 kg (52.7 lb)

\*1: California type

\*2: Non-California type

**ENGINE**

Model	GX100
Description code	GCANM
Type	4-stroke, overhead camshaft single cylinder
Displacement	98.5 cm <sup>3</sup> (6.01 cu-in)
Bore x stroke	56.0 x 40.0 mm (2.20x 1.57 in)
Compression ratio	8.5 ± 0.2 : 1
Cooling system	Forced air
Ignition system	Full transistor
Ignition timing	25° ± 2° B.T.D.C.
Spark plug	CR5HSB (NGK)
Carburetor	Float type, Horizontal butterfly valve type
Air cleaner	Semi-dry type
Governor	Electronic control type
Lubrication system	Forced splash
Oil capacity	0.40 ℓ (0.42 US qt, 0.35 Imp qt)
Recommended oil	SAE 10W-30
Starting system	Recoil starter
Stopping system	Ignition primary circuit ground
Fuel used	Regular unleaded gasoline (86 pump octane)

**EU2000i COMPANION****GENERATOR**

Model	EU2000i COMPANION
Description code	EAAJ
Generator type	Multi-pole field rotation type
Generator structure	Self-ventilation drip-proof type
Excitation	Self-excitation (Magnet type)
Voltage regulation system	PWM (Pulse Width Modulation)
Phase	Single phase
Rotating direction	Clockwise (Viewed from the generator)
Frequency regulation	DC-AC conversion (Inverter type)

**2. CHARACTERISTICS**

Model	EU2000i COMPANION	
Type	AC1, AN1	
Maximum output	2.0 kVA	
AC rated output	1.6 kVA	
Rated frequency	60 Hz	
AC rated voltage	120 V	
AC rated current	13.3 A	
Power factor	1.0 $\cos \theta$	
Voltage variation rate	Momentary	10 % max.
	Average	6% max.
	Average time	3 sec. max.
Voltage stability	$\pm 1$ % max.	
Frequency variation rate	Momentary	1 % max.
	Average	1 % max.
	Average time	1 sec. max.
Frequency stability	$\pm 0.1$ Hz max.	
Insulation resistance	10 M $\Omega$ min.	
AC circuit protector	18.7 A	
Fuel tank capacity	3.6 l (0.95 US gal, 0.79 Imp gal)	
Fuel consumption (at rated load)	1.07 l (0.28 US gal, 0.24 Imp gal)/Hr	
Operating hours (at rated load without refueling)	Approx. 3.4 Hr	
Noise level (LwA) (Rated)	LwA 89 dB (A)	

## **EU2000i COMPANION**

---

### **3. DIMENSIONAL DRAWINGS**

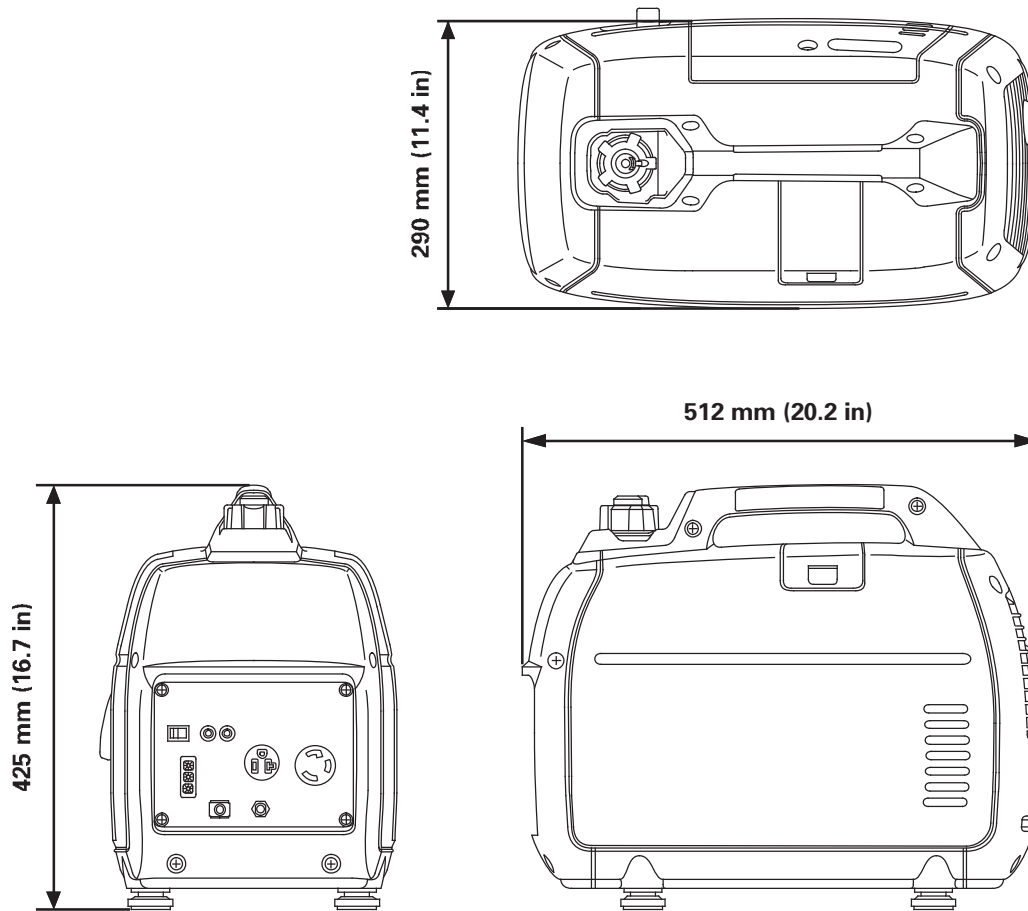





# EU2000i COMPANION

# 2. SERVICE INFORMATION

## 1. CABLE & HARNESS ROUTING..... 2-1

### 1. CABLE & HARNESS ROUTING

#### • CONTROL PANEL

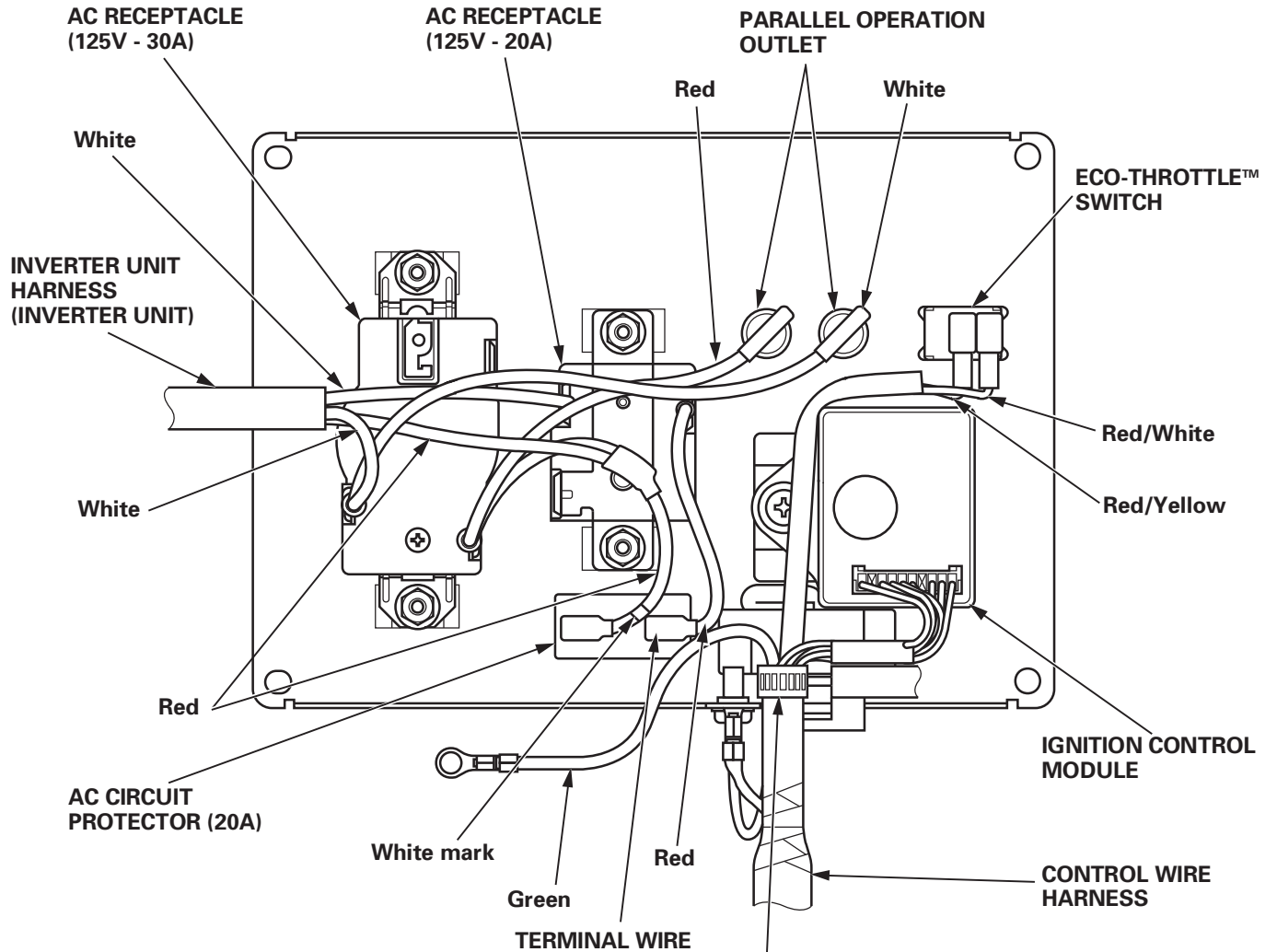

#### FRAME GROUND/HARNESS BAND

**INSTALLATION:**  
Install the band in the direction shown.

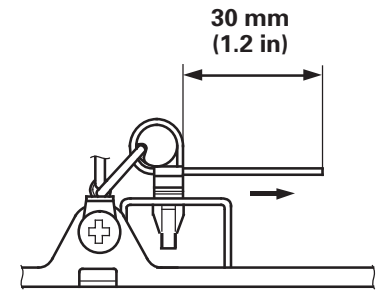

# **EU2000i COMPANION**

---

---

<b>1. CONTROL PANEL ..... 6-1</b>
-----------------------------------

# 1. CONTROL PANEL

## a. REMOVAL/INSTALLATION

- 1) Remove the four 5 x 16 mm tapping screws, and then disconnect the inverter unit harness that is connected to the inverter unit.
- 2) Remove the control panel assembly.
- 3) Remove the 5 x 12 mm bolt and ground wire.

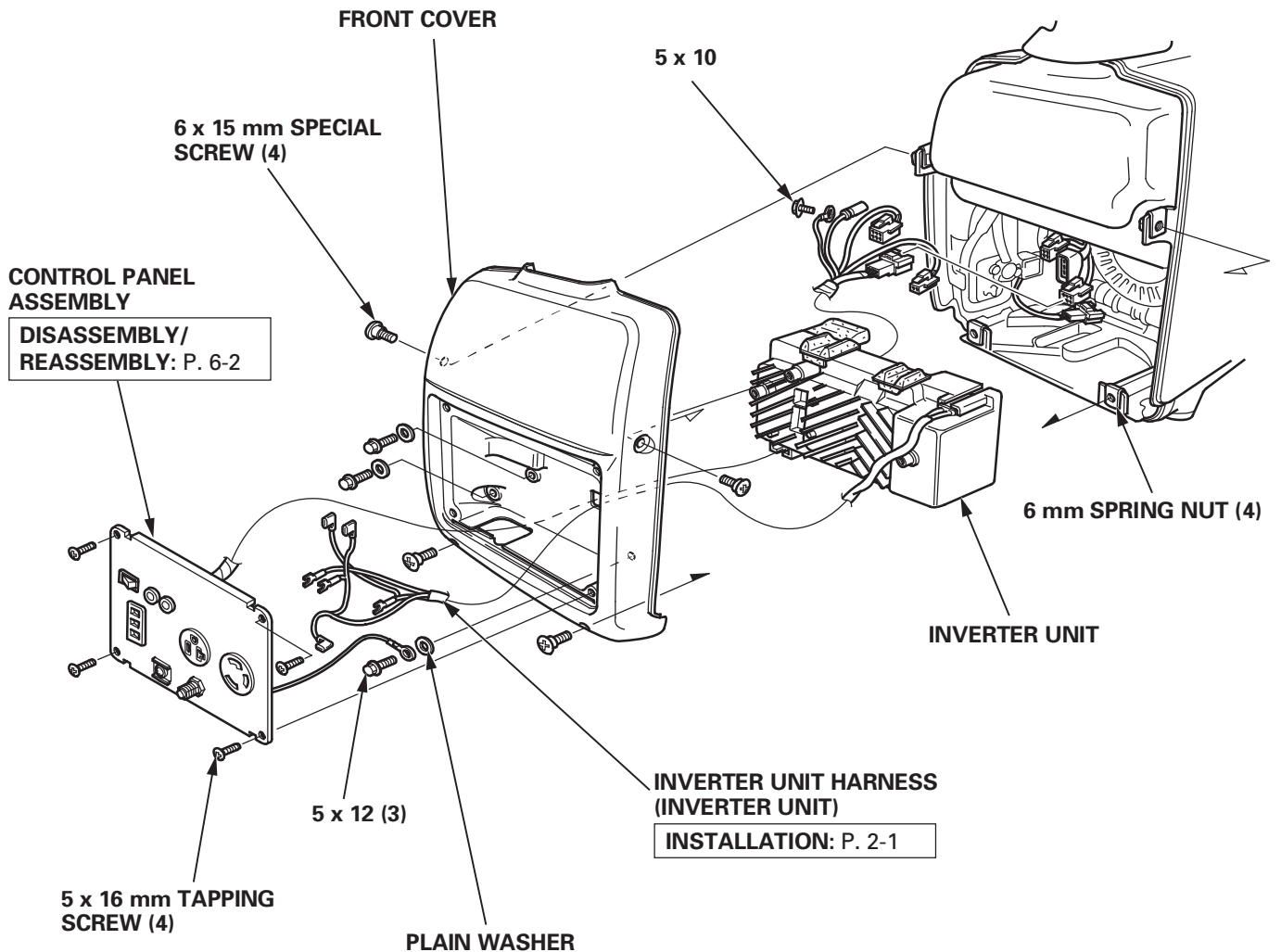

**b. DISASSEMBLY/REASSEMBLY**

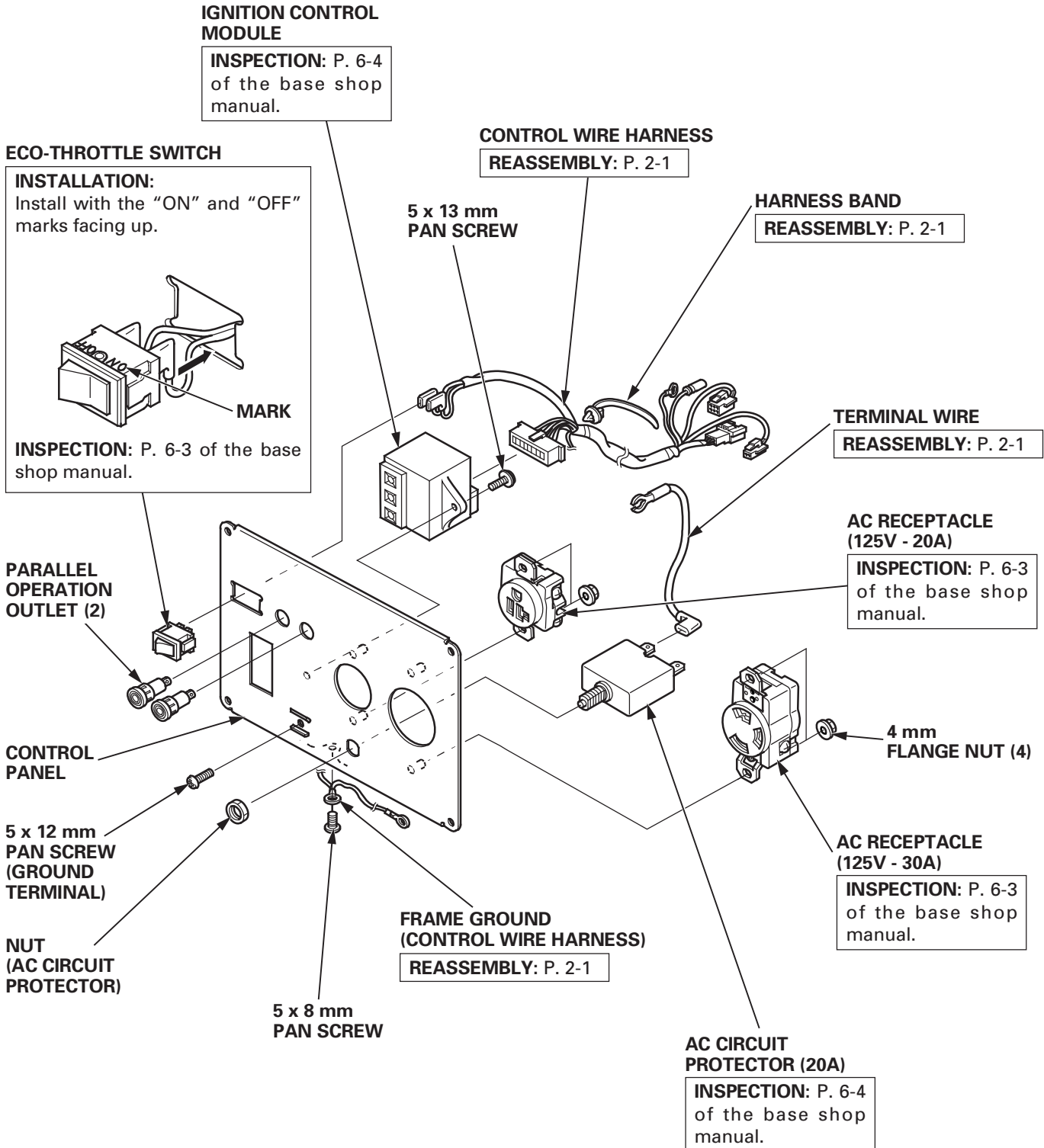

## NOTES

## NOTES

## NOTES





This document was created with Win2PDF available at <http://www.win2pdf.com>.  
The unregistered version of Win2PDF is for evaluation or non-commercial use only.  
This page will not be added after purchasing Win2PDF.